

DATA SHEET

- Type.....ASA 90L-2
- Reference standard.....IEC 60034-1
EN 60079-0
EN 60079-1
EN 60079-7
- Rated output.....2.2 kW
- Rated stator voltage.....400V
- Stator current at 100% load4.58 [A]
- Number of poles.....2
- Rated speed.....2820 rev/min
- Rated frequency.....50 Hz
- Efficiency at 100% load.....81.5%
- Power factor at 100% load.....0.85
- Break-down torque.....2.8 x Mn
- Locked rotor torque.....2.8 x Mn
- Locked rotor current.....5 x In
- Rotor inertia.....0.003181 kgm²
- Insulation class.....F
- Direction of rotation.....Both(CW&CCW)
- Protection degree.....≥IP55
- Mounting.....IM
- Cooling method.....IC 411
- Max. ambient temperature.....+40°C
- Altitude.....1000m
- Bearing type.....6305 2Z drive end
6305 2Z non drive end
- Outline drawing.....Page 2
- Weight.....32 Kg
- Vibration level :A (acc.IEC 60034-14)
- Noise levelacc.IEC 60034-9
- Cable entries.....1xM25x1.5
- Climate executionN

**The overall and mounting dimensions
IM 1001**

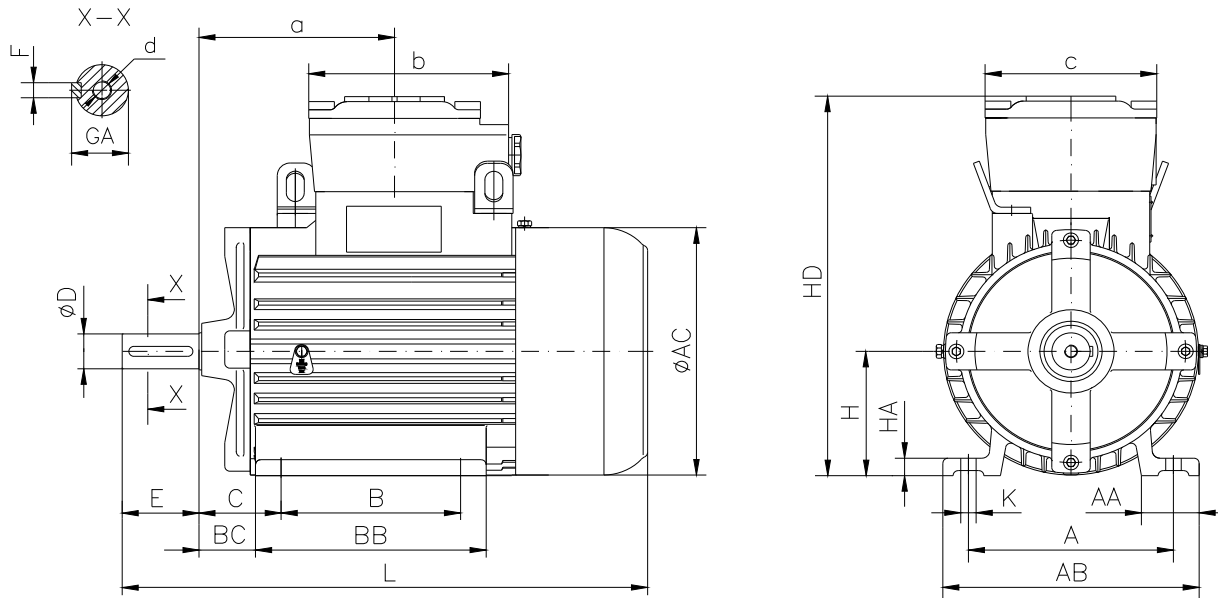

Frame size	Dimensions (mm)																				
	Foot mounting										Shaft extension					HD	AC	L	a	b	c
90L-2	A	B	C	H _{0.5}	K	AA	AB	BB	BC	HA	D	E	F	GA	d						
	140	125	56	90	10	40	180	172	39.5	13	24j6	50	8h9	27	M8	272	177	361	140	125	120

**The overall and mounting dimensions
IM 3001; IM 3011**

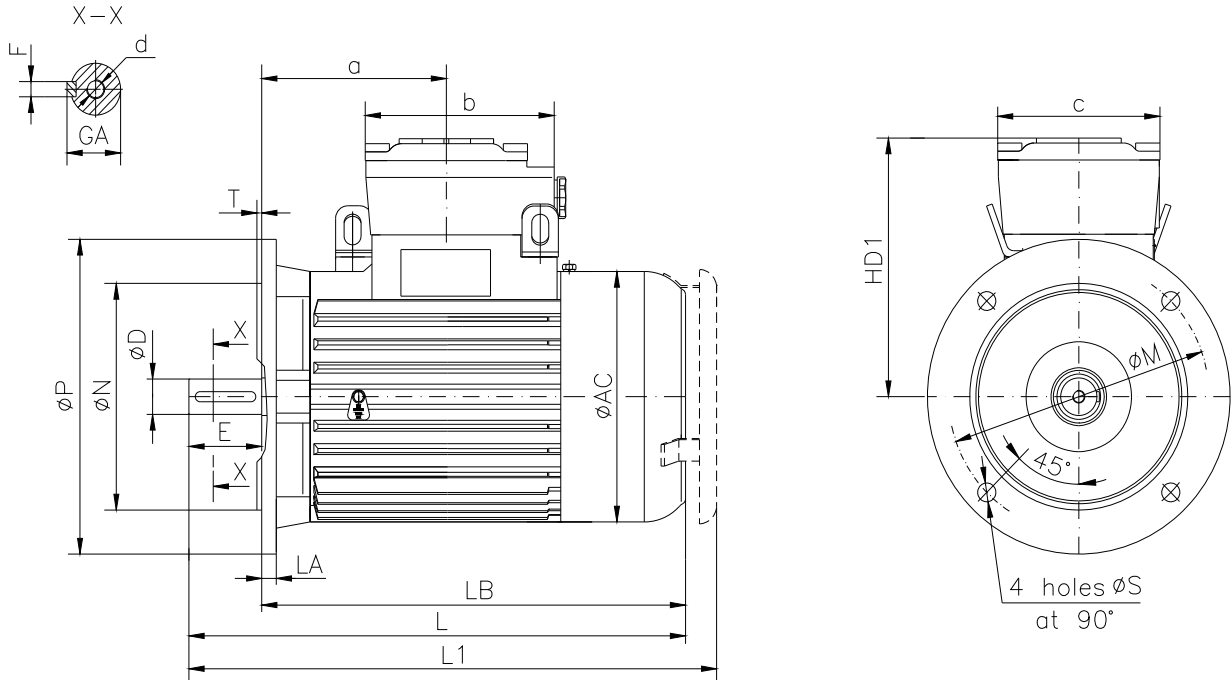

Frame size	Dimensions (mm)											HD1	AC	LA	LB	L	L1	a	b	c
	Flange mounting (B5)					Shaft extension														
	N	M	P	S	T	D	E	F	GA	d										
90L-2	130j6	165	200	12	3.5	24j6	50	8h9	27	M8	182	177	10	311	361	392	140	125	120	

**The overall and mounting dimensions
IM 3601**

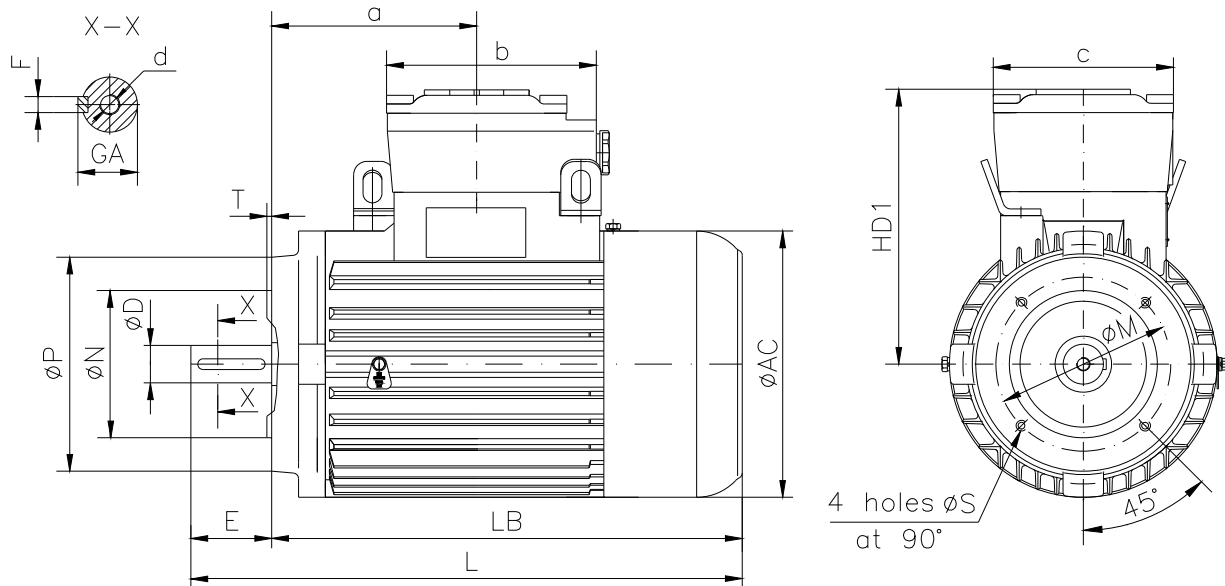

Frame size	Flange	Dimensions (mm)													
		Flange mounting (B14)					Shaft extension		HD1	AC	LB	L	a	b	c
N	M	P	S	T	D	E									
90L-2	F115	95j6	115	140	M8	3	24j6	50	182	177	311	361	140	125	120
	F130	110j6	130	160	M8	3.5									

**The overall and mounting dimensions
IM 2001**

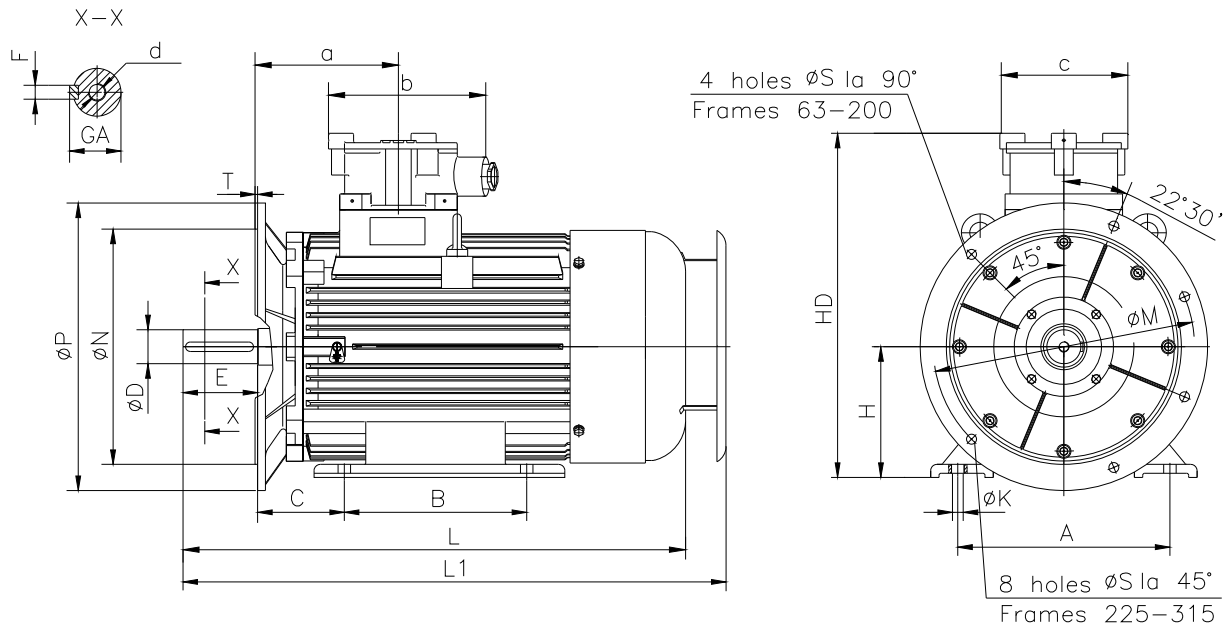

Frame size	Dimensions (mm)																				
	Foot mounting					Flange mounting					Shaft extension					HD	L	L1	a	b	c
90L-2	A	B	C	H _{0.5}	K	N	M	P	S	T	D	E	F	GA	d						
	140	125	56	90	10	130j6	165	200	12	3.5	24j6	50	8h9	27	M8	272	361	392	140	125	120