

DATA SHEET

- Type.....ASA 80b-8
- Reference standard.....IEC 60034-1
EN 60079-0
EN 60079-1
EN 60079-7
- Rated output.....0.25 kW
- Rated stator voltage.....400V
- Stator current at 100% load.....0.91[A]
- Number of poles.....8
- Rated speed.....700 rev/min
- Rated frequency.....50 Hz
- Efficiency at 100% load.....62%
- Power factor at 100% load.....0.64
- Break-down torque.....3.3 x Mn
- Locked rotor torque.....3.2 x Mn
- Locked rotor current.....3 x In
- Rotor inertia.....0.003987 kgm²
- Insulation class.....F
- Direction of rotation.....Both(CW&CCW)
- Protection degree.....≥IP55
- Mounting.....IM
- Cooling method.....IC 411
- Max. ambient temperature.....+40°C
- Altitude.....1000m
- Bearing type.....6304 2Z drive end
6304 2Z non drive end
- Weight.....23 Kg
- Outline drawing.....Page 2
- Vibration level :.....A (acc.IEC 60034-14)
- Noise levelacc.IEC 60034-9
- Cable entries.....1xM25x1.5
- Climate executionN

**The overall and mounting dimensions
IM 1001**

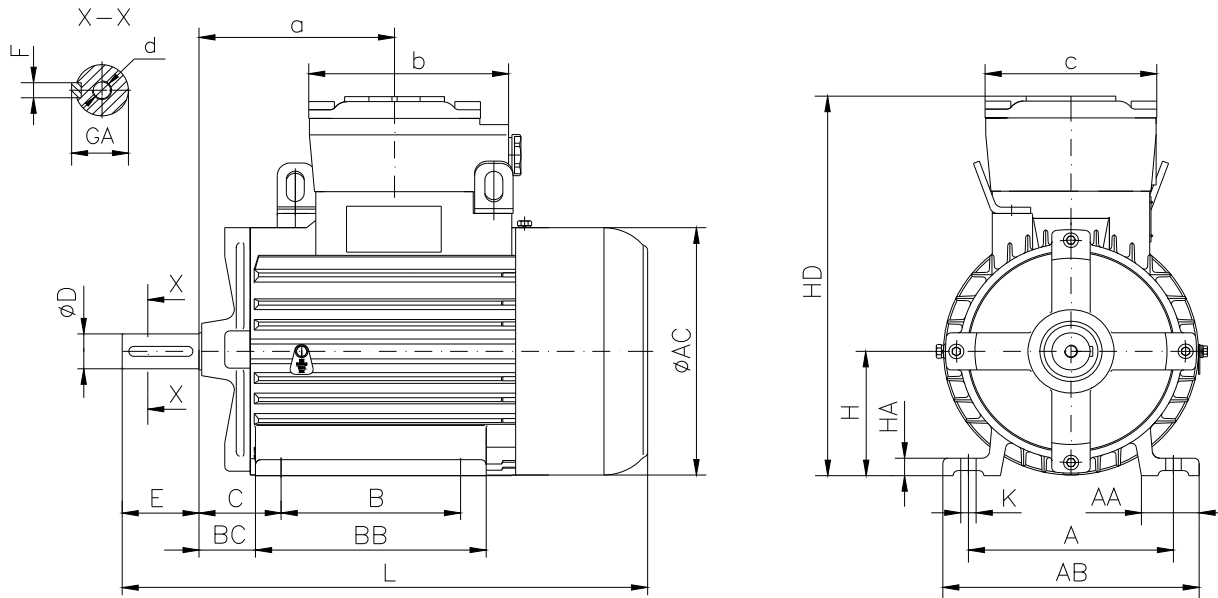

Frame size	Dimensions (mm)																				
	Foot mounting										Shaft extension					HD	AC	L	a	b	c
80b-8	A	B	C	H _{0.5}	K	AA	AB	BB	BC	HA	D	E	F	GA	d						
	125	100	50	80	10	35	160	152	35.5	12	19j6	40	6h9	21.5	M6	254	158	315	125	125	120

**The overall and mounting dimensions
IM 3001; IM 3011**

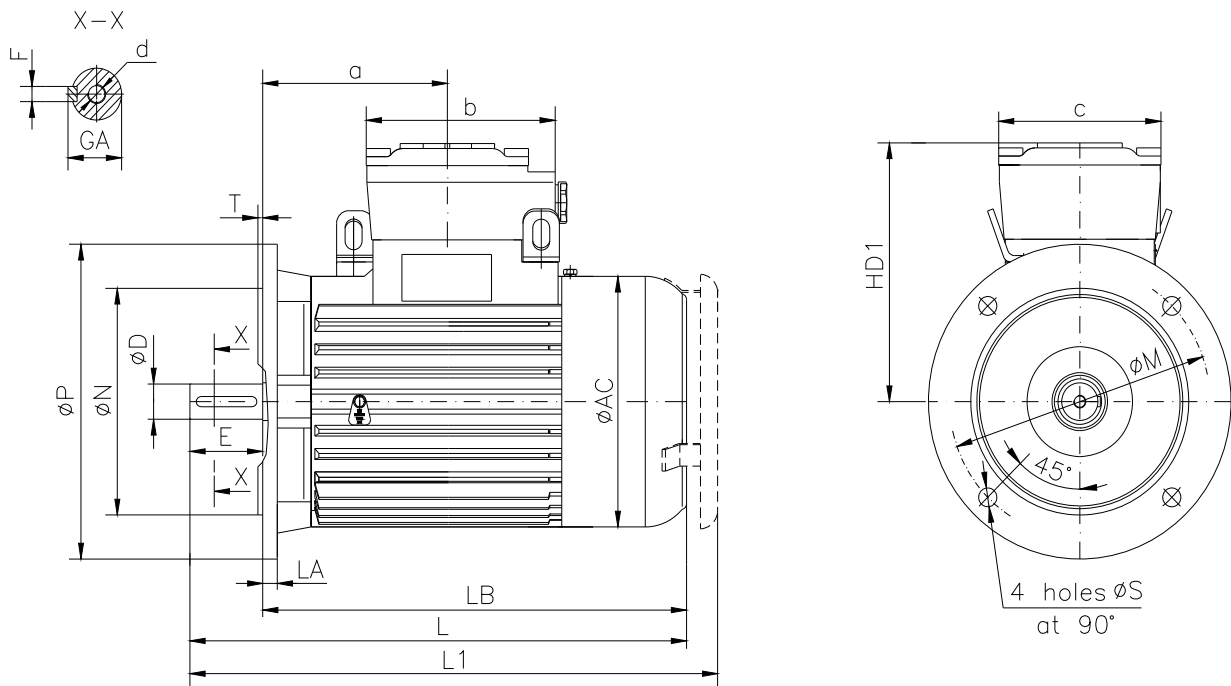

Frame size	Dimensions (mm)																		
	Flange mounting (B5)					Shaft extension					HD1	AC	LA	LB	L	L1	a	b	c
N	M	P	S	T	D	E	F	GA	d										
80b-8	130j6	165	200	12	3.5	19j6	40	6h9	21.5	M6	174	158	10	275	315	346	125	125	120

**The overall and mounting dimensions
IM 3601**

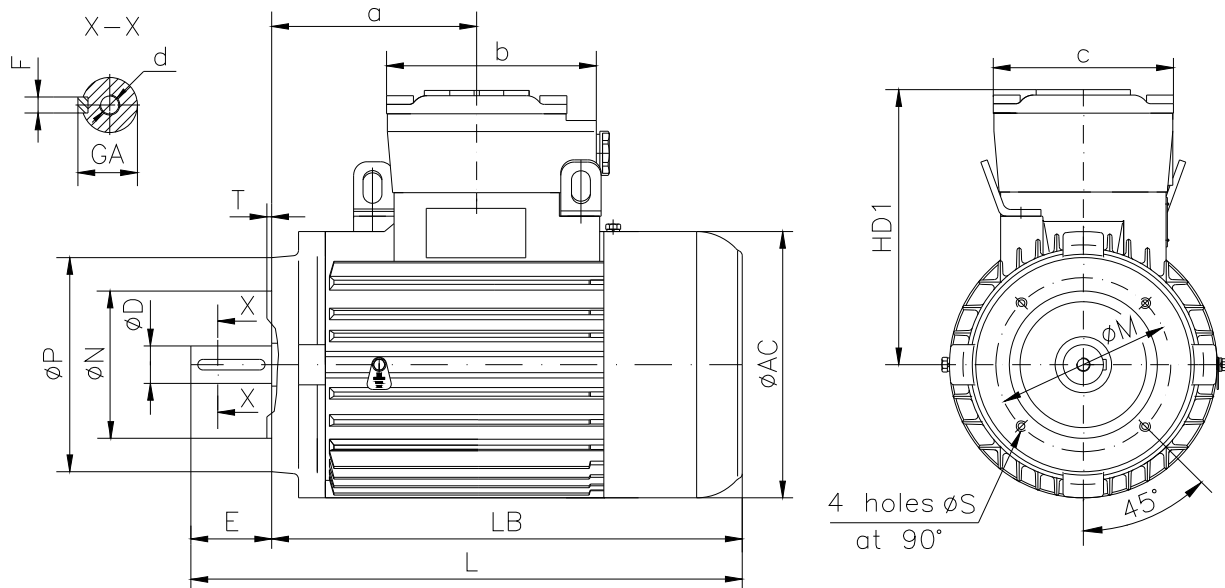

Frame size	Flange	Dimensions (mm)													
		Flange mounting (B14)					Shaft extension		HD1	AC	LB	L	a	b	c
		N	M	P	S	T	D	E							
80b-8	F100	80j6	100	120	M6	3	19j6	40	174	158	275	315	125	125	120
	F130	110j6	130	160	M8	3.5									

