

DATA SHEET

○ Type.....	ASA 80a-8
○ Reference standard.....	IEC 60034-1 EN 60079-0 EN 60079-1 EN 60079-7
○ Rated output.....	0.18 kW
○ Rated stator voltage.....	400V
○ Stator current at 100% load.....	0.8 [A]
○ Number of poles.....	8
○ Rated speed.....	705 rev/min
○ Rated frequency.....	50 Hz
○ Efficiency at 100% load.....	53%
○ Power factor at 100% load.....	0.61
○ Break-down torque.....	3.3 x Mn
○ Locked rotor torque.....	3.1 x Mn
○ Locked rotor current.....	2.9 x In
○ Rotor inertia.....	0.002818 kgm ²
○ Insulation class.....	F
○ Direction of rotation.....	Both(CW&CCW)
○ Protection degree.....	≥IP55
○ Mounting.....	IM
○ Cooling method.....	IC 411
○ Max. ambient temperature.....	+40°C
○ Altitude.....	1000m
○ Bearing type.....	6304 2Z drive end 6304 2Z non drive end
○ Weight.....	22 Kg
○ Outline drawing.....	Page 2
○ Vibration level :.....	A (acc.IEC 60034-14)
○ Noise level	acc.IEC 60034-9
○ Cable entries.....	1xM25x1.5
○ Climate execution	N

**The overall and mounting dimensions
IM 1001**

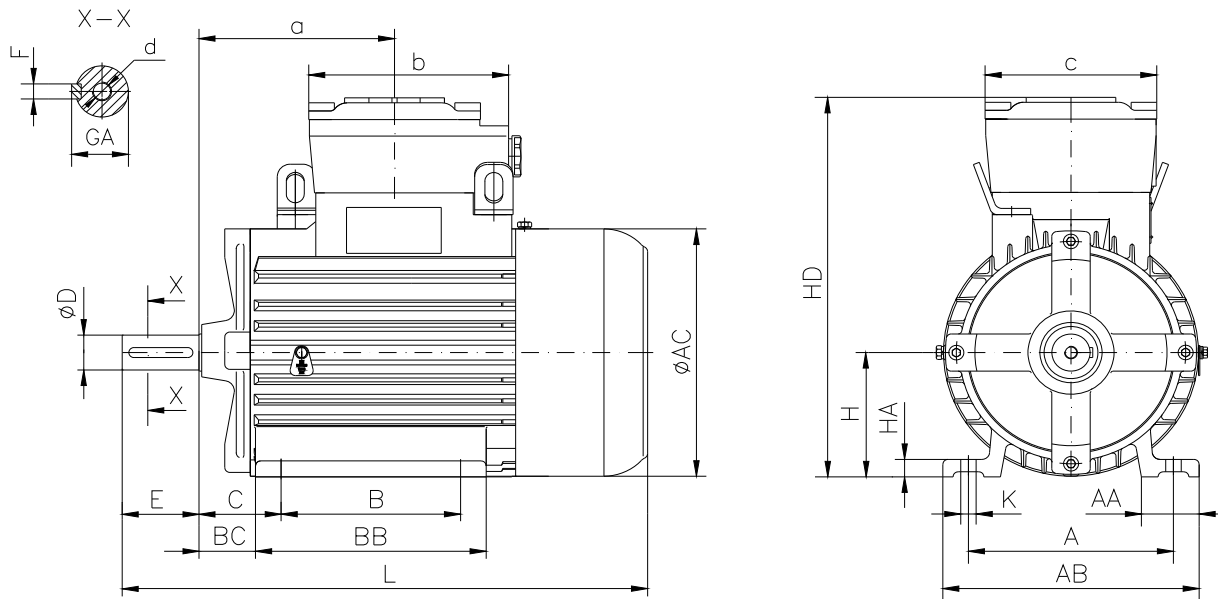

Frame size	Dimensions (mm)																				
	Foot mounting										Shaft extension					HD	AC	L	a	b	c
A	B	C	H _{L0.5}	K	AA	AB	BB	BC	HA	D	E	F	GA	d							
80a-8	125	100	50	80	10	35	160	152	35.5	12	19j6	40	6h9	21.5	M6	254	158	315	125	125	120

**The overall and mounting dimensions
IM 3001; IM 3011**

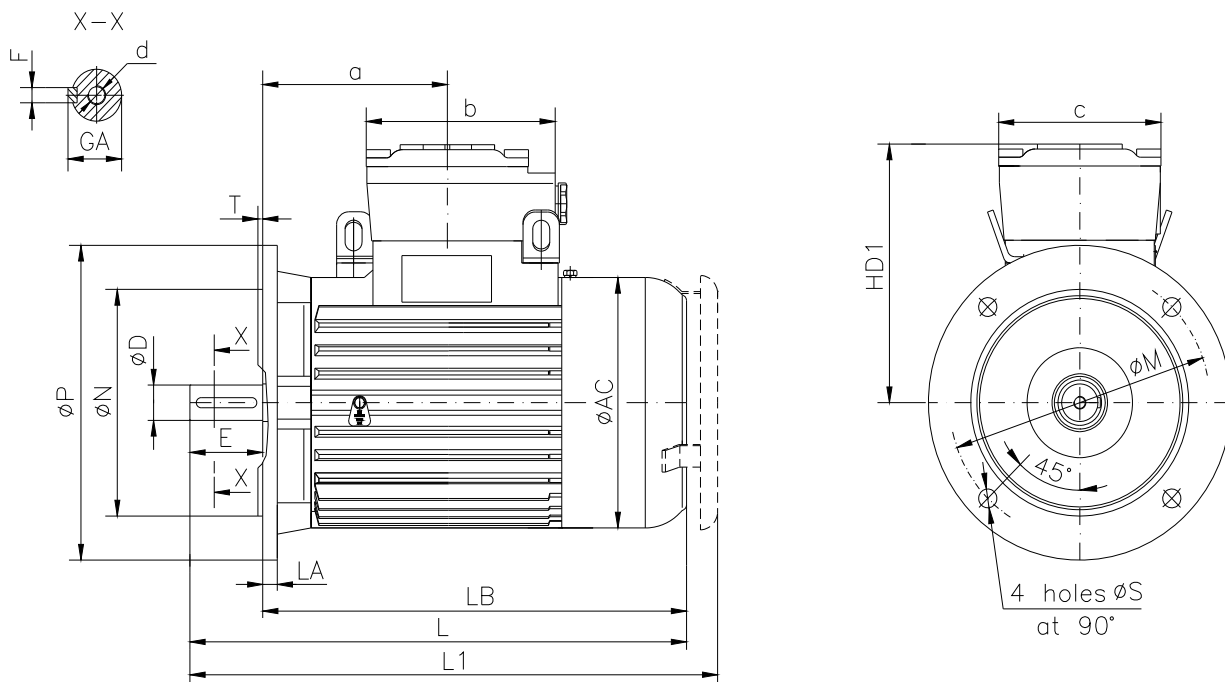

Frame size	Dimensions (mm)										HD1	AC	LA	LB	L	L1	a	b	c
	Flange mounting (B5)					Shaft extension													
80a-8	N	M	P	S	T	D	E	F	GA	d									
	130j6	165	200	12	3.5	19j6	40	6h9	21.5	M6	174	158	10	275	315	346	125	125	120

**The overall and mounting dimensions
IM 3601**

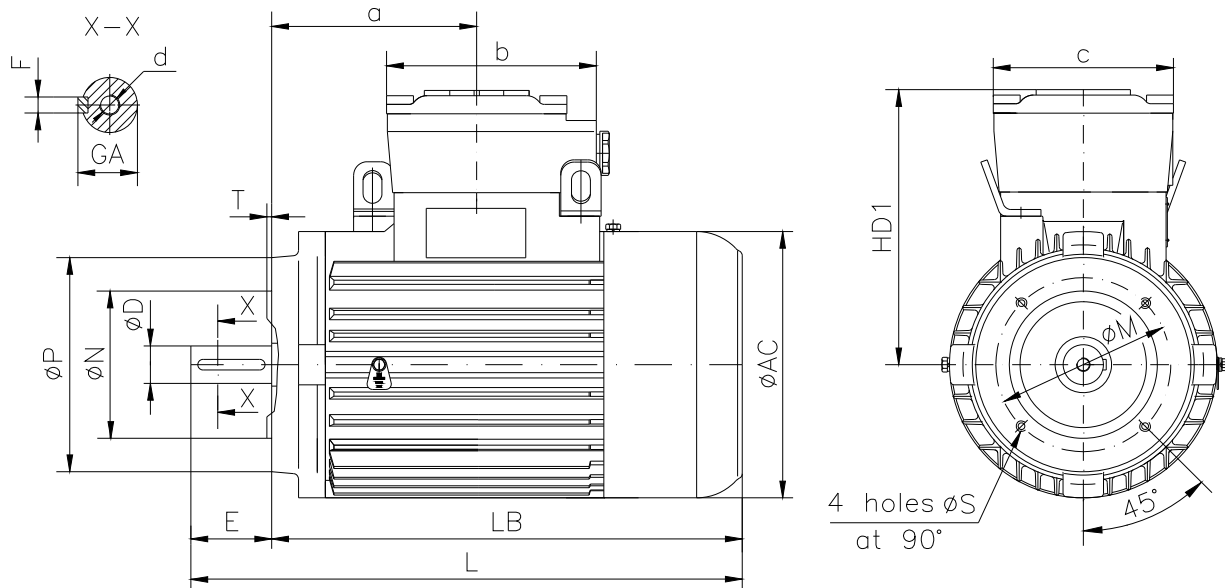

Frame size	Flange	Dimensions (mm)													
		Flange mounting (B14)					Shaft extension		HD1	AC	LB	L	a	b	c
		N	M	P	S	T	D	E							
80a-8	F100	80j6	100	120	M6	3	19j6	40	174	158	275	315	125	125	120
	F130	110j6	130	160	M8	3.5									

**The overall and mounting dimensions
IM 2001**

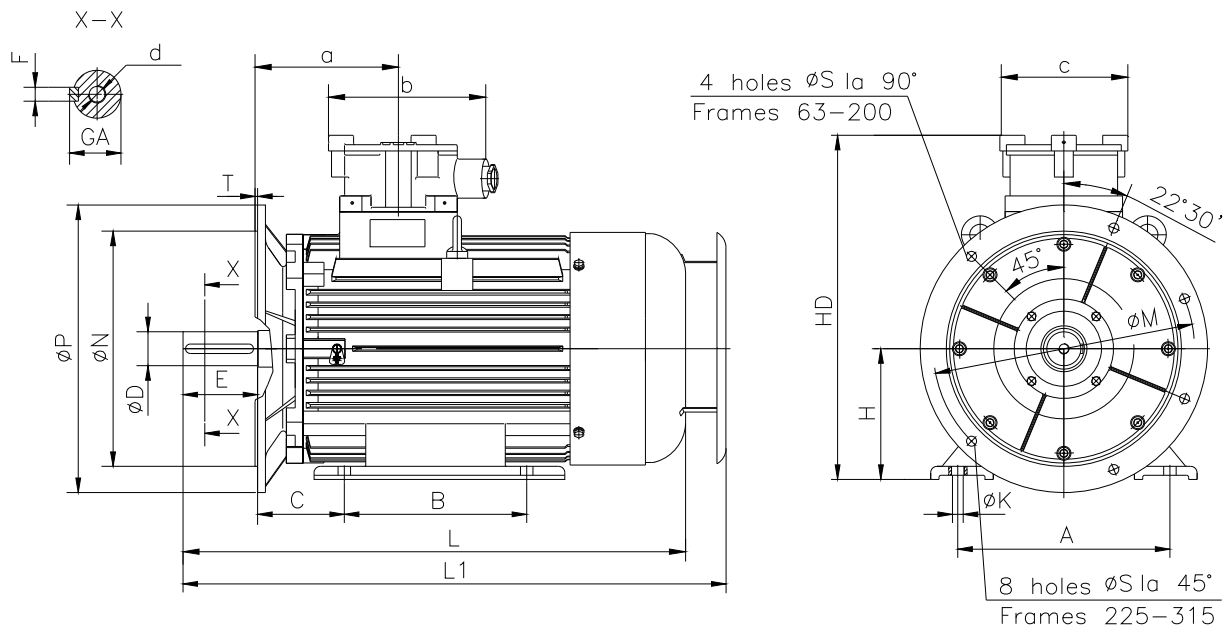

Frame size	Dimensions (mm)																				
	Foot mounting					Flange mounting					Shaft extension					HD	L	L1	a	b	c
80a-8	A	B	C	H _{0.5}	K	N	M	P	S	T	D	E	F	GA	d						
	125	100	50	80	10	130j6	165	200	12	3.5	19j6	40	6h9	21.5	M6	254	315	346	125	125	120