

**DATA SHEET**

○ Type.....	ASA 315MX-4
○ Reference standard.....	IEC 60034-1 EN 60079-0 EN 60079-1 EN 60079-7
○ Rated output.....	160 kW
○ Rated stator voltage.....	400 V
○ Stator current at 100% load.....	280 A
○ Rated frequency.....	50 Hz
○ Number of poles.....	4
○ Rated speed.....	1484 rev/min
○ Efficiency at 100% load.....	94.7%
○ Power factor at 100% load.....	0.87
○ Break-down torque.....	2.2 x Mn
○ Locked rotor torque.....	2.1 x Mn
○ Locked rotor current.....	6.5 x In
○ Rotor inertia.....	3.309 kgm <sup>2</sup>
○ Insulation class.....	F
○ Direction of rotation.....	Both(CW&CCW)
○ Protection degree.....	≥IP55
○ Mounting.....	IM
○ Cooling method.....	IC 411
○ Max. ambient temperature.....	+40°C
○ Altitude.....	1000m
○ Bearing type.....	6319 drive end 6319 non drive end
○ Lubrication.....	regreasable bearings with UNIREX N2, Shell Alvania R3, SKF LGTH3 or similar
○ Relubricating interval .....	8700 hrs DE and NDE
○ Correcting interval.....	3000 hrs DE and NDE
○ Grease quantity .....	45g/bearing DE and NDE
○ Weight.....	1150 Kg
○ Outline drawing.....	Page 2
○ Thermal winding protection.....	3xPTC
○ Vibration level :.....	A(acc.IEC 60034-14)
○ Noise level .....	acc.IEC 60034-9
○ Cable entries.....	2xM63x1.5
○ Additional cable entries.....	1xM20x1.5
○ Climate execution .....	N

**The overall and mounting dimensions  
IM 1001**

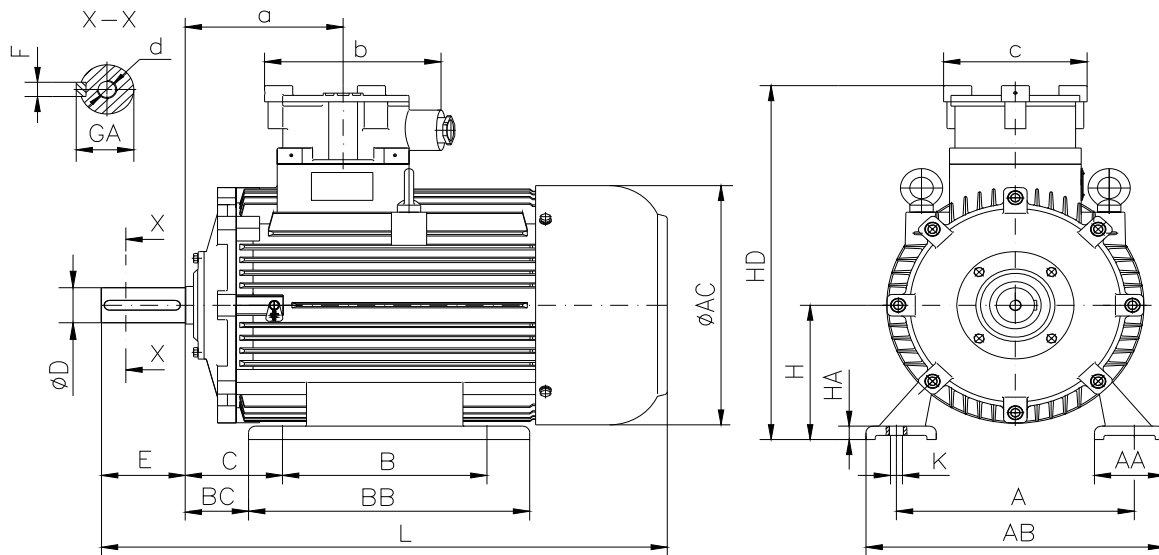

Frame size	Dimensions (mm)																				
	Foot mounting										Shaft extension					HD	AC	L	a	b	c
315 MX-4	A	B	C	H <sub>0.5</sub>	K	AA	AB	BB	BC	HA	D	E	F	GA	d	880	620	1290	320	460	355
	508	457	216	315	28	120	630	588	176	26	80m6	170	22h9	85	M20						

**The overall and mounting dimensions  
IM 3001; IM 3011**

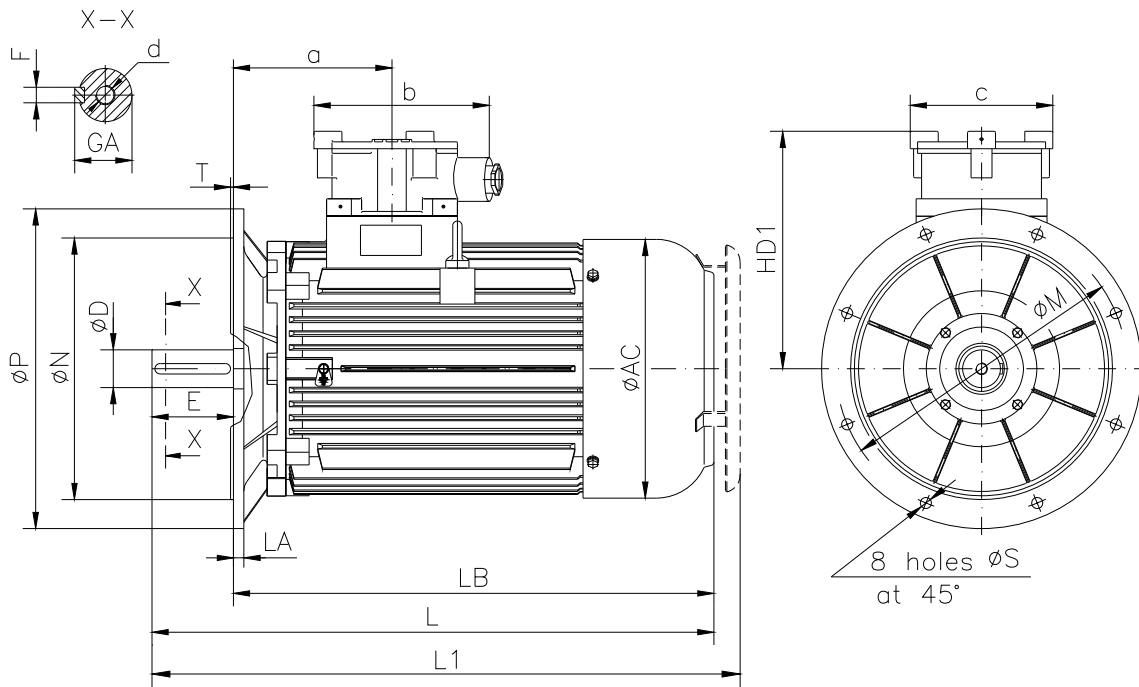

Frame size	Dimensions (mm)																			
	Flange mounting (B5)					Shaft extension						HD1	AC	LA	LB	L	L1	a	b	c
N	M	P	S	T	D	E	F	GA	d											
315 MX-4	550j6	600	660	24	6	80m6	170	22h9	85	M20	565	520	25	1110	1290	1390	320	460	355	

**The overall and mounting dimensions  
IM 2001**

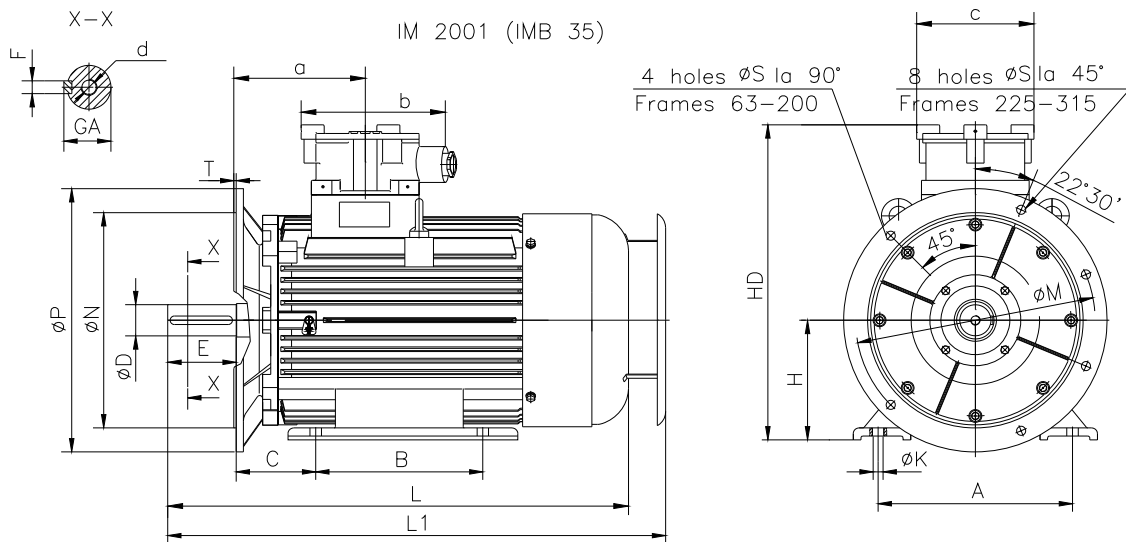

Frame size	Dimensions (mm)																				
	Foot mounting					Flange mounting					Shaft extension					HD	L	L1	a	b	c
315 MX-4	A	B	C	H <sub>0.5</sub>	K	N	M	P	S	T	D	E	F	GA	d						
	508	457	216	315	28	550j6	600	660	24	6	80m6	170	22h9	85	M20	880	1290	1390	320	360	355