

DATA SHEET

○ Type.....	ASA 315M-8
○ Reference standard.....	IEC 60034-1 EN 60079-0 EN 60079-1 EN 60079-7
○ Rated output.....	75 kW
○ Rated stator voltage.....	400 V
○ Rated frequency.....	50 Hz
○ Stator current at 100% load.....	142 A
○ Number of poles.....	8
○ Rated speed.....	740rev/min
○ Efficiency at 100% load.....	93%
○ Power factor at 100% load.....	0.82
○ Break-down torque.....	2.0 x Mn
○ Locked rotor torque.....	1.8 x Mn
○ Locked rotor current.....	5.5 x In
○ Rotor inertia.....	3.042 kgm ²
○ Insulation class.....	F
○ Direction of rotation.....	Both(CW&CCW)
○ Protection degree.....	≥IP55
○ Mounting.....	IM
○ Cooling method.....	IC 411
○ Max. ambient temperature.....	+40°C
○ Altitude.....	1000m
○ Bearing type.....	6317 drive end 6315 non drive end
○ Lubrication.....	regreasable bearings with UNIREX N2, Shell Alvania R3, SKF LGTH3 or similar
○ Relubricating interval.....	10000[hrs] drive end 11400[hrs] non drive end
○ Correcting interval.....	3500[hrs] drive end 4000[hrs] non drive end
○ Grease quantity	37g/bearing drive end 30g/bearing non drive end
○ Thermal winding protection.....	3xPTC
○ Weight.....	880 Kg
○ Outline drawing.....	Page 2
○ Vibration level :	A (acc.IEC 60034-14)
○ Noise level	acc.IEC 60034-9
○ Cable entries.....	2xM63x1.5
○ Additional cable entries.....	1xM20x1.5
○ Climate execution	N

**The overall and mounting dimensions
IM 1001**

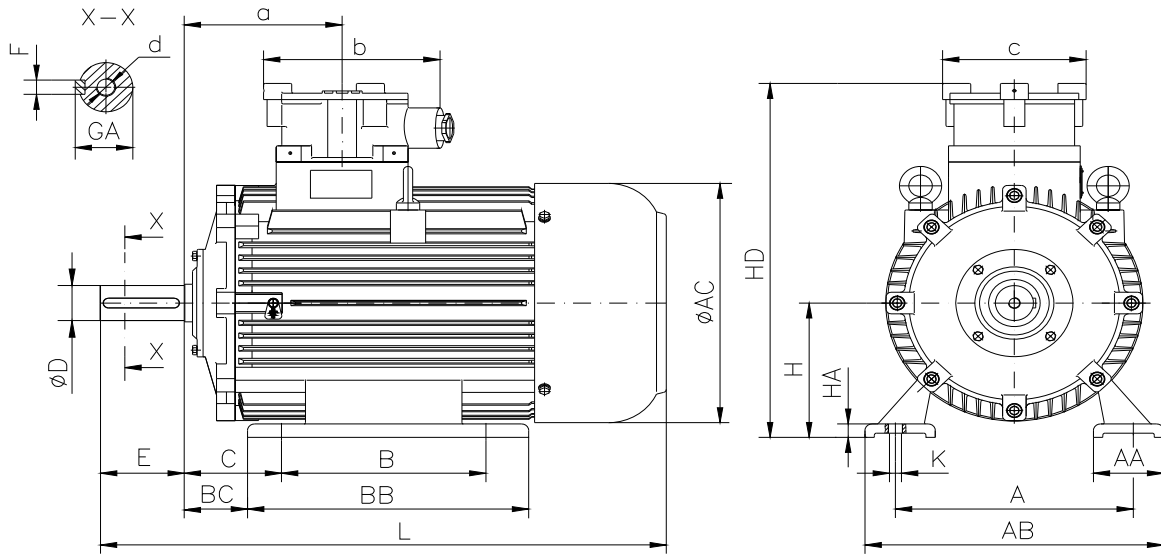

Frame size	Dimensions (mm)																				
	Foot mounting										Shaft extension						HD	AC	L	a	b
A	B	C	H _{0.5}	K	AA	AB	BB	BC	HA	D	E	F	GA	d							
315 M-8	508	457	216	315	28	130	630	568	151.5	30	80m6	170	22h9	85	M20	826	560	1265	300	340	300

**The overall and mounting dimensions
IM 3001; IM 3011**

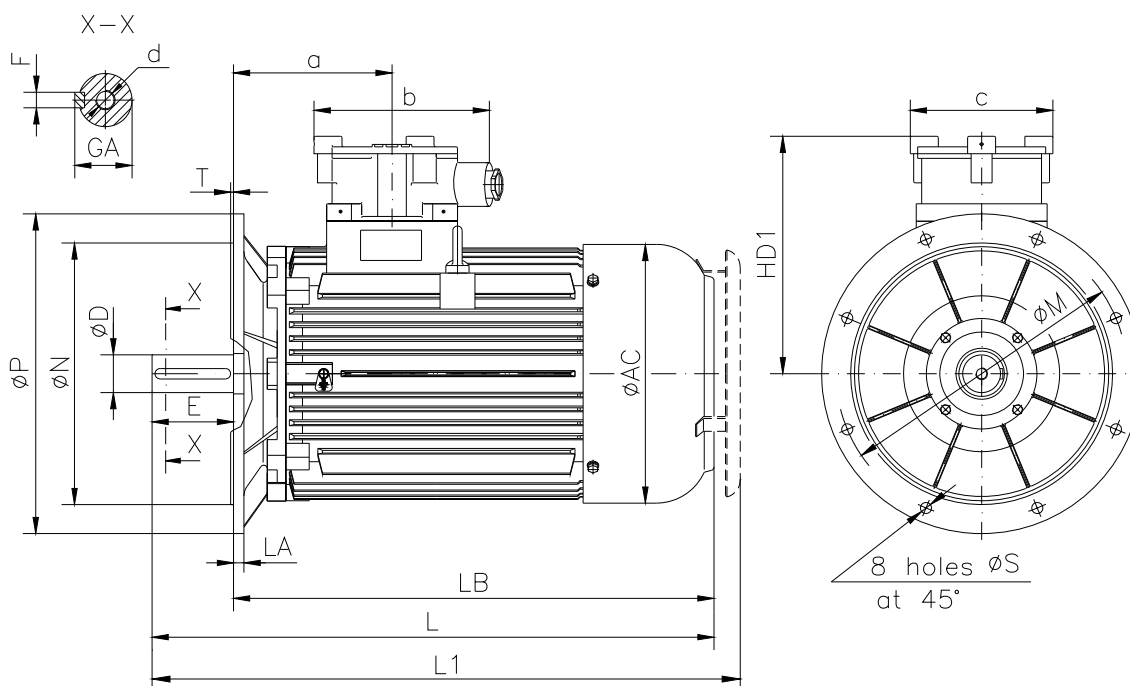

Frame size	Dimensions (mm)																		
	Flange mounting (B5)					Shaft extension					HD1	AC	LA	LB	L	L1	a	b	c
N	M	P	S	T	D	E	F	GA	d										
315 M-8	550j6	600	660	24	6	80m6	170	22h9	85	M20	511	560	20	1090	1265	1365	300	340	300

**The overall and mounting dimensions
IM 2001**

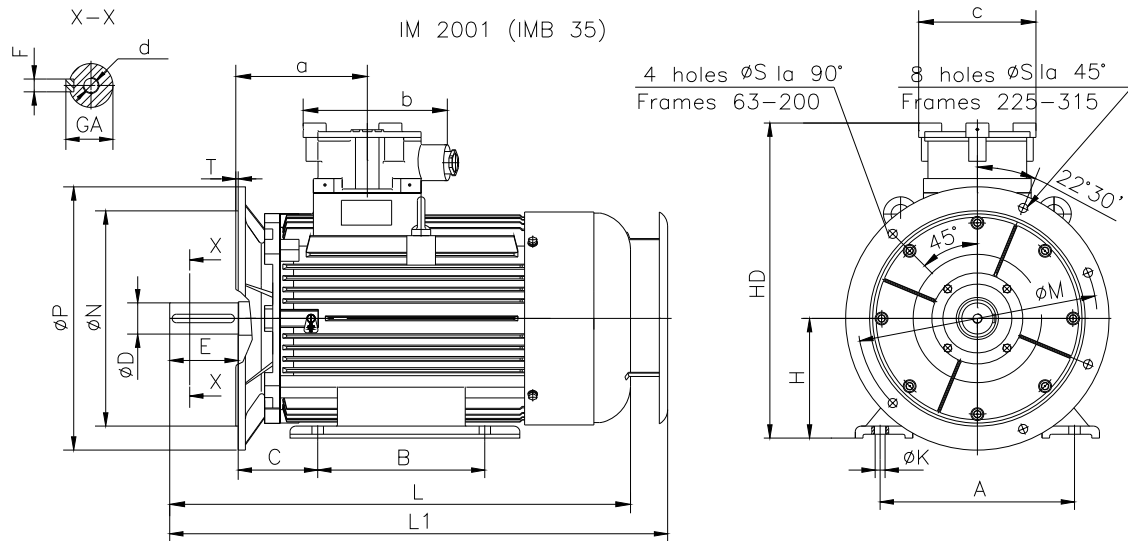

Frame size	Dimensions (mm)																				
	Foot mounting					Flange mounting					Shaft extension					HD	L	L1	a	b	c
	A	B	C	H _{0,5}	K	N	M	P	S	T	D	E	F	GA	d						
315 M-8	508	457	216	315	28	550j6	600	660	24	6	80m6	170	22h9	85	M20	826	1265	1365	300	340	300