

**DATA SHEET**

○ Type.....	ASA 280S-4
○ Reference standard.....	IEC 60034-1 EN 60079-0 EN 60079-1 EN 60079-7
○ Rated output.....	75 kW
○ Rated stator voltage.....	400 V
○ Rated frequency.....	50Hz
○ Stator current at 100% load.....	127 A
○ Number of poles.....	4
○ Rated speed.....	1480 rev/min
○ Efficiency at 100% load.....	93.8%
○ Power factor at 100% load.....	0.91
○ Break-down torque.....	2.4 x Mn
○ Locked rotor torque.....	2.4 x Mn
○ Locked rotor current.....	7.25 x In
○ Rotor inertia .....	0.9375 kgm <sup>2</sup>
○ Insulation class.....	F
○ Direction of rotation.....	Both(CW&CCW)
○ Protection degree.....	≥IP55
○ Mounting.....	IM
○ Cooling method.....	IC 411
○ Max. ambient temperature.....	+40°C
○ Altitude.....	1000m
○ Bearing type.....	6316 drive end 6314 non drive end
○ Lubrication.....	regreasable bearings with UNIREX N2, Shell Alvania R3, SKF LGTH3
○ Relubricating interval.....	10700 hrs DE 12100 hrs NDE
○ Correcting interval.....	3700 hrs DE 4200 hrs NDE
○ Grease quantity .....	33g/bearing DE 26 g/bearing NDE
○ Thermal winding protection.....	3xPTC
○ Weight.....	640 Kg
○ Outline drawing.....	Page 2
○ Vibration level : .....	A(acc.IEC 60034-14)
○ Noise level .....	acc.IEC 60034-9
○ Cable entries.....	2xM63x1.5
○ Additional cable entries.....	1xM20x1.5
○ Climate execution .....	N

**The overall and mounting dimensions  
IM 1001**

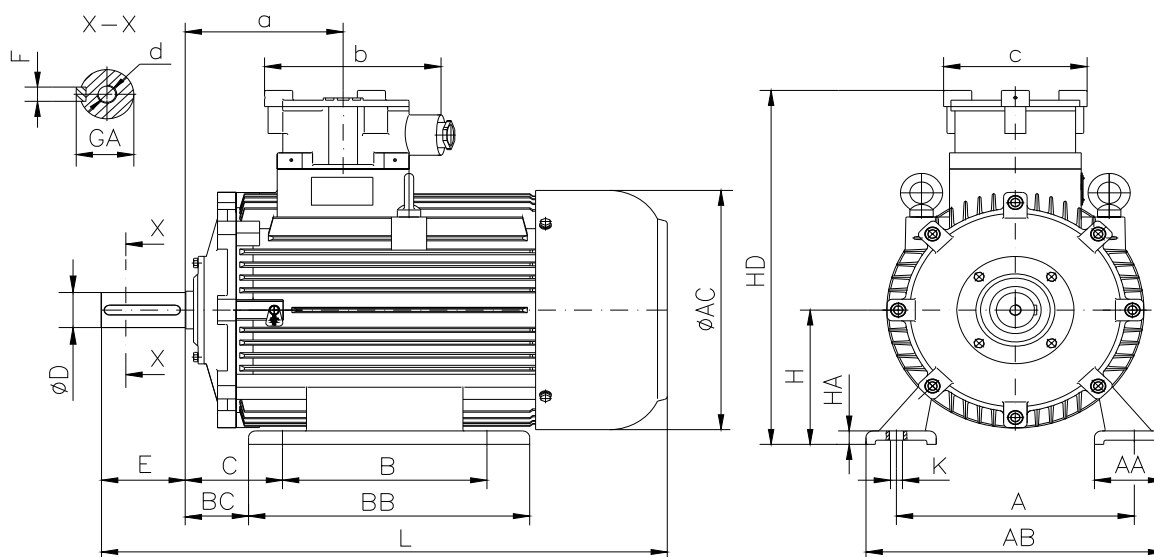

Frame size	Dimensions (mm)																				
	Foot mounting										Shaft extension					HD	AC	L	a	b	c
A	B	C	H <sub>0.5</sub>	K	AA	AB	BB	BC	HA	D	E	F	GA	d							
280 S-4	457	368	190	280	24	120	550	460	147	30	75m6	140	20h9	79.5	M20	758	500	1045	280	340	300

**The overall and mounting dimensions  
IM 3001; IM 3011**

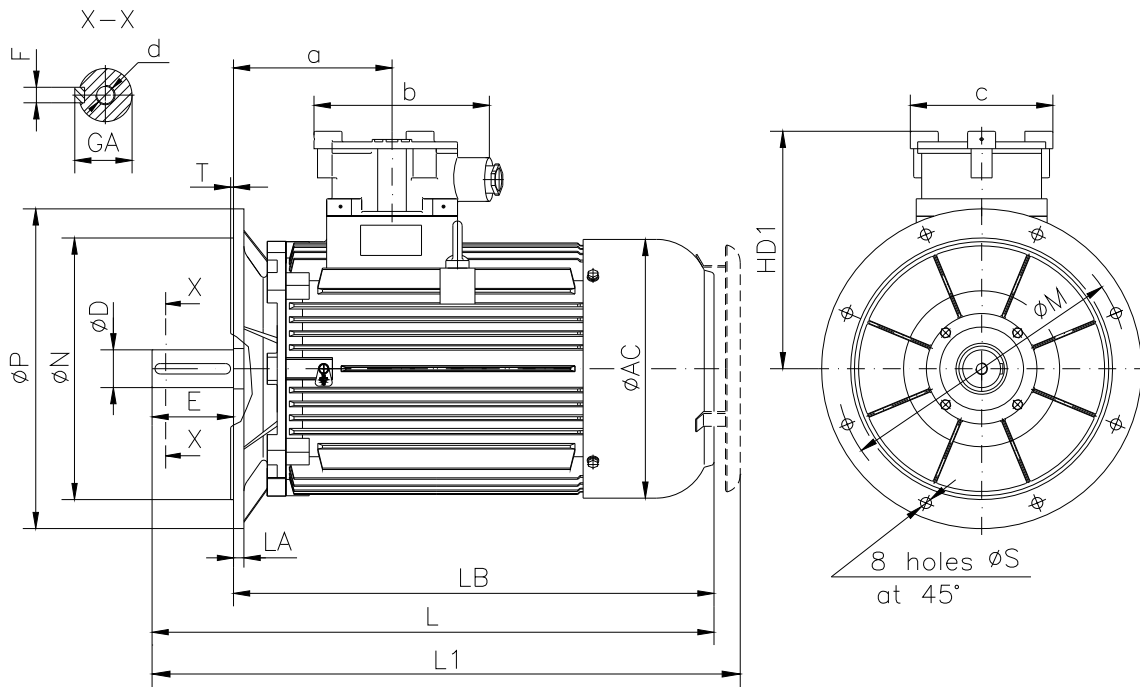

Frame size	Dimensions (mm)																		
	Flange mounting (B5)					Shaft extension					HD1	AC	LA	LB	L	L1	a	b	c
N	M	P	S	T	D	E	F	GA	d										
280 S-4	450j6	500	550	18.5	5	75m6	140	20h9	79.5	M20	478	500	20	902	1045	1150	280	340	300

**The overall and mounting dimensions  
IM 2001**

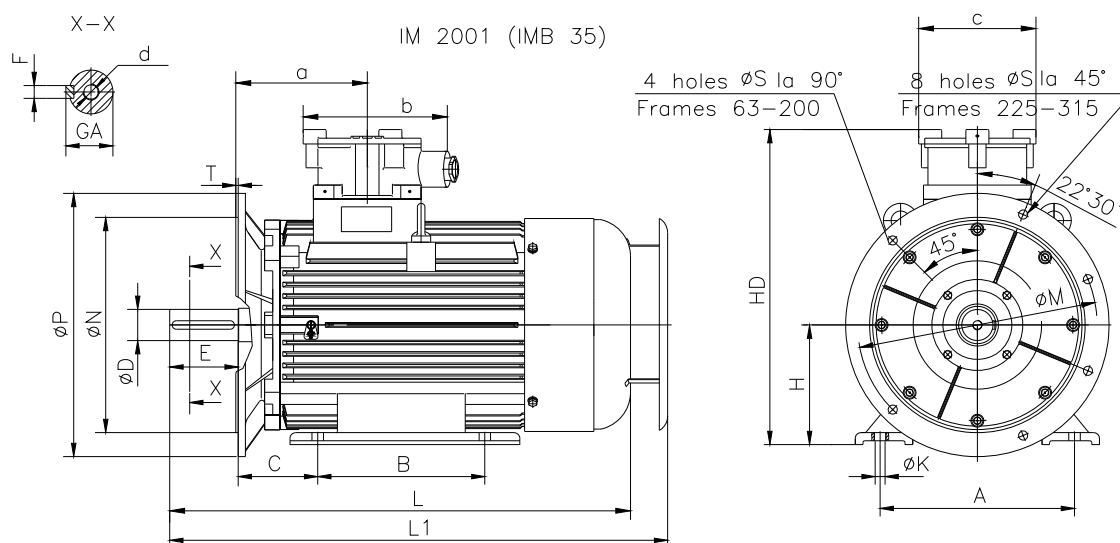

Frame size	Dimensions (mm)																				
	Foot mounting					Flange mounting					Shaft extension					HD	L	L1	a	b	c
280 S-4	A	B	C	H <sub>0,5</sub>	K	N	M	P	S	T	D	E	F	GA	d						
	457	368	190	280	24	450j6	500	550	18.5	5	75m6	140	20h9	79.5	M20	758	1045	1150	280	340	300