

**DATA SHEET**

○ Type.....	ASA 280M-8
○ Reference standard.....	IEC 60034-1 EN 60079-0 EN 60079-1 EN 60079-7
○ Rated output.....	45 kW
○ Rated stator voltage.....	400 V
○ Rated frequency.....	50 Hz
○ Stator current at 100% load.....	88.3 A
○ Number of poles.....	8
○ Rated speed.....	730 rev/min
○ Efficiency at 100% load.....	92%
○ Power factor at 100% load.....	0.8
○ Break-down torque.....	2.5 x Mn
○ Locked rotor torque.....	2.1 x Mn
○ Locked rotor current.....	6.2 x In
○ Rotor inertia.....	1.614 kgm <sup>2</sup>
○ Insulation class.....	F
○ Direction of rotation.....	Both(CW&CCW)
○ Protection degree.....	≥IP55
○ Mounting.....	IM
○ Cooling method.....	IC 411
○ Max. ambient temperature.....	+40°C
○ Altitude.....	1000m
○ Bearing type.....	6316 drive end 6314 non drive end
○ Lubrication.....	regreasable bearings with UNIREX N2, Shell Alvania R3, SKF LGTH3
○ Relubricating interval.....	10700 hrs DE 12100 hrs NDE
○ Correcting interval.....	3700 hrs DE 4200 hrs NDE
○ Grease quantity .....	33g/bearing DE 26 g/bearing NDE
○ Thermal winding protection.....	3xPTC
○ Weight.....	690 Kg
○ Outline drawing.....	Page 2
○ Vibration level : .....	A (acc.IEC 60034-14 )
○ Noise level .....	acc.IEC 60034-9
○ Cable entries.....	2xM63x1.5
○ Additional cable entries.....	1xM20x1.5
○ Climate execution .....	N

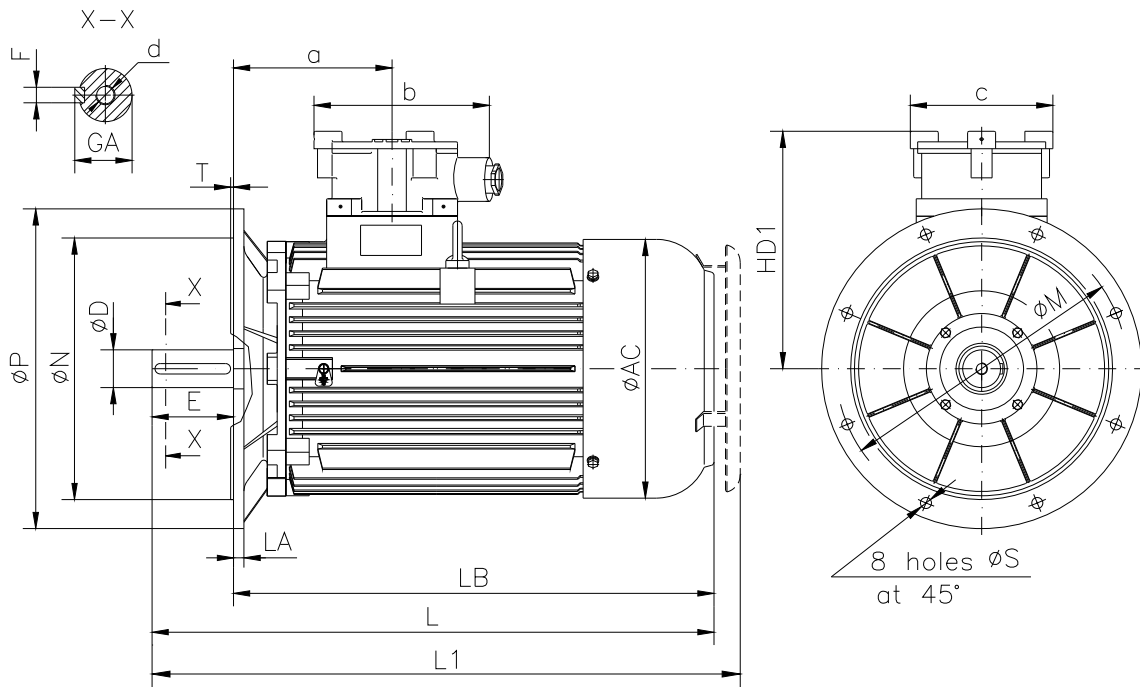

**The overall and mounting dimensions  
IM 3001; IM 3011**



Frame size	Dimensions (mm)																		
	Flange mounting (B5)					Shaft extension					HD1	AC	LA	LB	L	L1	a	b	c
N	M	P	S	T	D	E	F	GA	d										
280 M-8	450j6	500	550	18.5	5	75m6	140	20h9	79.5	M20	478	500	20	942	1085	1190	280	340	300

**The overall and mounting dimensions  
IM 2001**

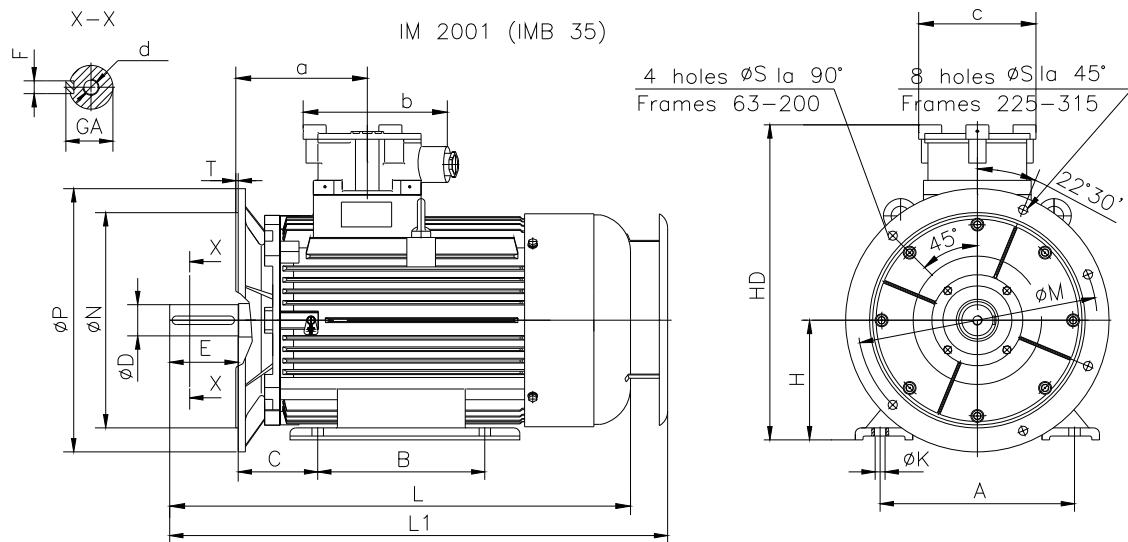

Frame size	Dimensions (mm)																				
	Foot mounting				Flange mounting					Shaft extension					HD	L	L1	a	b	c	
280 M-8	A	B	C	H <sub>0,5</sub>	K	N	M	P	S	T	D	E	F	GA	d						
	457	419	190	280	24	450j6	500	550	18.5	5	75m6	140	20h9	79.5	M20	758	1085	1190	280	340	300