

DATA SHEET

○ Type.....	ASA 112M-8
○ Reference standard.....	IEC 60034-1
	EN 60079-0
	EN 60079-1
	EN 60079-7
○ Rated output.....	1.5 kW
○ Rated stator voltage.....	400V
○ Stator current at 100% load.....	4.08 [A]
○ Number of poles.....	8
○ Rated speed.....	725 rev/min
○ Rated frequency.....	50 Hz
○ Efficiency at 100% load.....	74.7%
○ Power factor at 100% load.....	0.71
○ Break-down torque.....	1.9 x Mn
○ Locked rotor torque.....	1.4 x Mn
○ Locked rotor current.....	4.5 x In
○ Rotor inertia.....	0.021573 kgm ²
○ Insulation class.....	F
○ Direction of rotation.....	Both(CW&CCW)
○ Protection degree.....	≥IP55
○ Mounting.....	IM
○ Cooling method.....	IC 411
○ Max. ambient temperature.....	+ 40°C
○ Altitude.....	1000m
○ Bearing type.....	6307 2Z drive end 6307 2Z non drive end
○ Weight.....	58 Kg
○ Outline drawing.....	Page 2
○ Vibration level :.....	A (acc.IEC 60034-14)
○ Noise level	acc.IEC 60034-9
○ Cable entries.....	2xM32x1.5
○ Climate execution	N

**The overall and mounting dimensions
IM 1001**

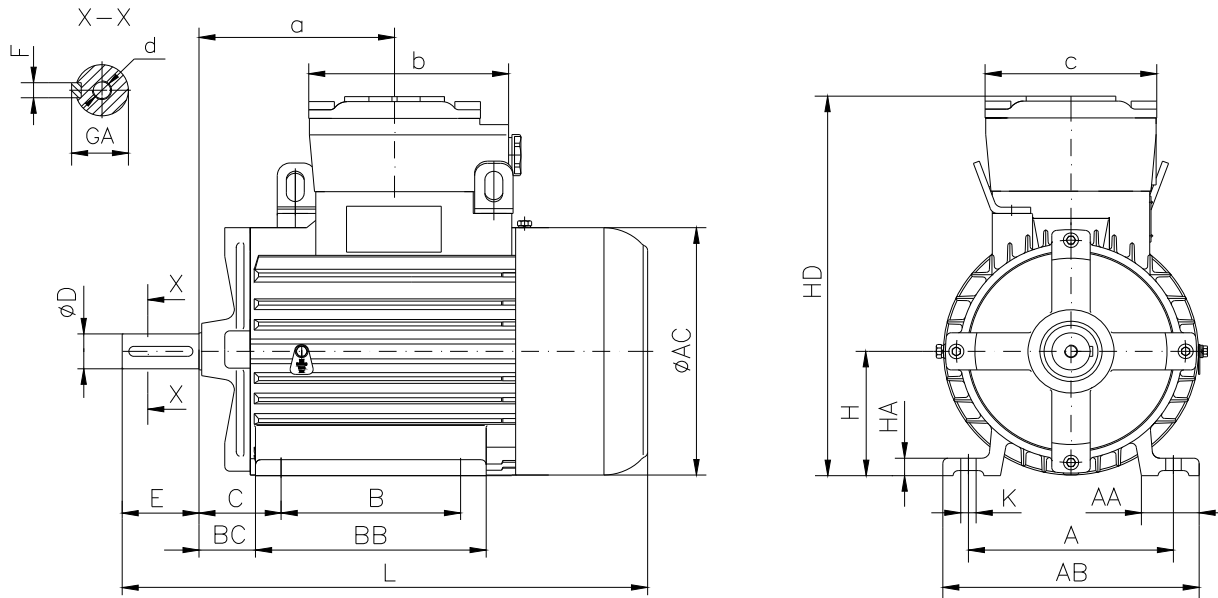

Frame size	Dimensions (mm)																				
	Foot mounting										Shaft extension					HD	AC	L	a	b	c
112 M-8	A	B	C	H _{0.5}	K	AA	AB	BB	BC	HA	D	E	F	GA	d						
	190	140	70	112	12	45	224	200	50	15	28j6	60	8h9	31	M10	332	221	456	175	160	135

**The overall and mounting dimensions
IM 3001; IM 3011**

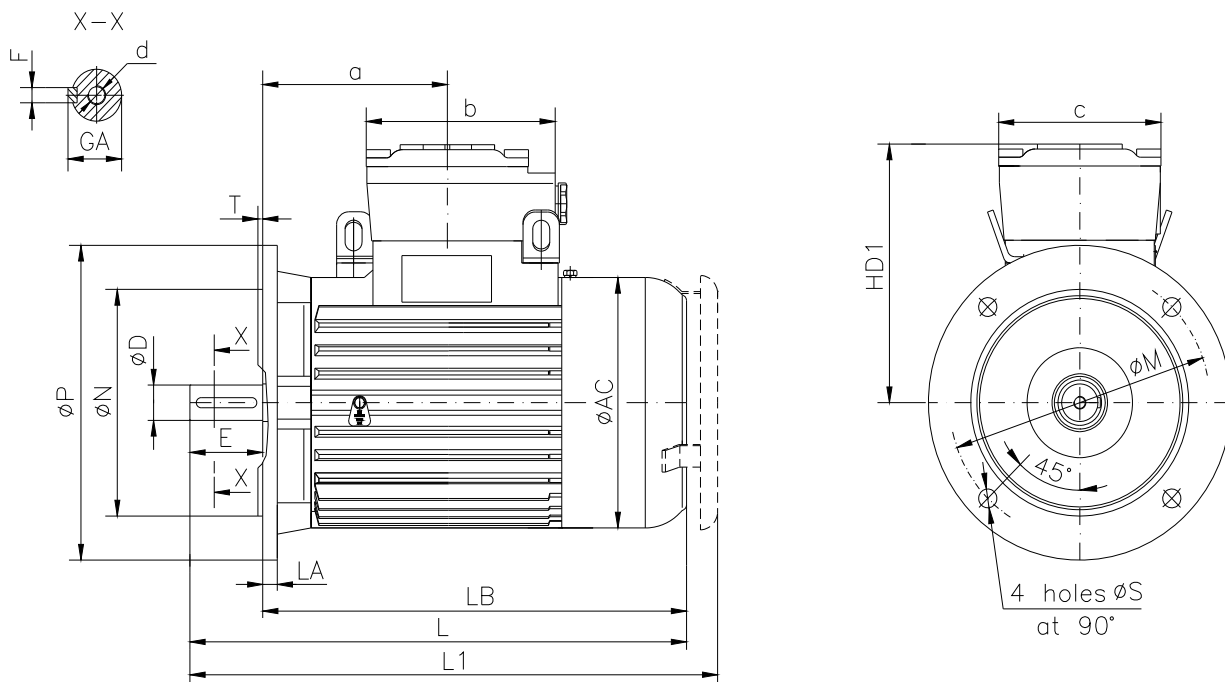

Frame size	Dimensions (mm)																		
	Flange mounting (B5)					Shaft extension					HD1	AC	LA	LB	L	L1	a	b	c
112 M-8	N	M	P	S	T	D	E	F	GA	d									
	180j6	215	250	14.5	4	28j6	60	8h9	31	M10	220	221	12	396	456	474	175	160	135

**The overall and mounting dimensions
IM 3601**

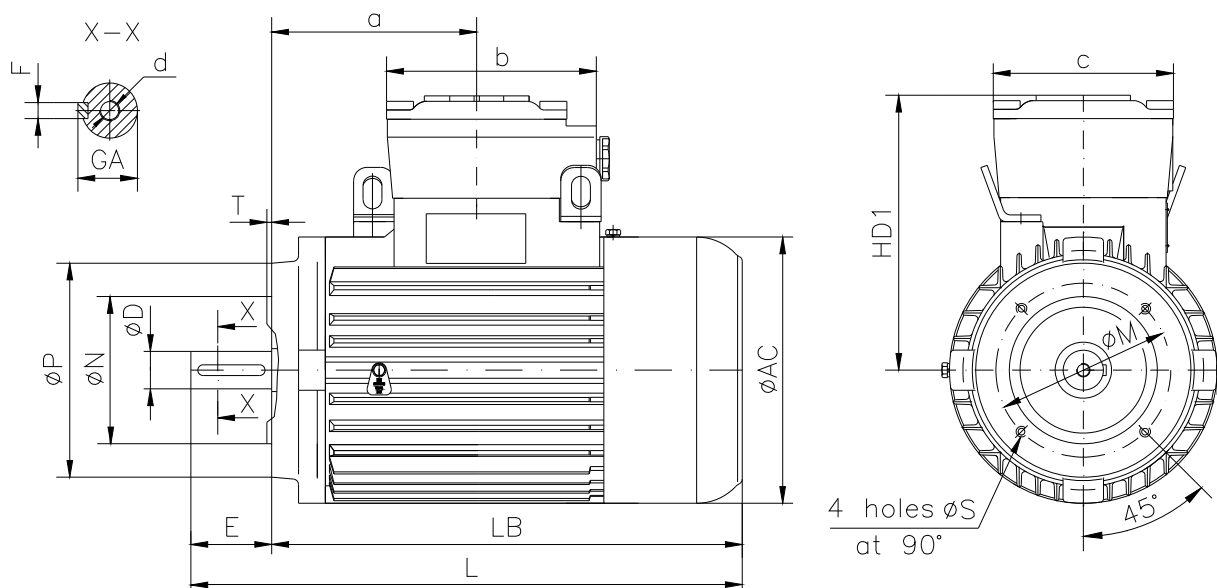

Frame size	Flange	Dimensions (mm)													
		Flange mounting (B14)					Shaft extension		HD1	AC	LB	L	a	b	c
N	M	P	S	T	D	E									
112 M-8	F130	110j6	130	160	M8	3.5	28j6	60	220	221	396	456	175	160	135
	F165	130j6	165	200	M10										

