

DATA SHEET

○ Type.....	ASA 100LW-2
○ Reference standard.....	IEC 60034-1 EN 60079-0 EN 60079-1 EN 60079-7
○ Rated output.....	3 kW
○ Rated stator voltage.....	400V
○ Stator current at 100% load.....	5.82[A]
○ Number of poles.....	2
○ Rated speed.....	2880 rev/min
○ Rated frequency.....	50 Hz
○ Efficiency at 100% load.....	83.6%
○ Power factor at 100% load.....	0.89
○ Break-down torque.....	3.3 x Mn
○ Locked rotor torque.....	3.1 x Mn
○ Locked rotor current.....	5.5 x In
○ Rotor inertia.....	0.005303 kgm ²
○ Insulation class.....	F
○ Direction of rotation.....	Both(CW&CCW)
○ Protection degree.....	≥IP55
○ Mounting.....	IM
○ Cooling method.....	IC 411
○ Max. ambient temperature.....	+40°C
○ Altitude.....	1000m
○ Bearing type.....	6306 2Z drive end 6306 2Z non drive end
○ Weight.....	46 Kg
○ Outline drawing.....	Page 2
○ Vibration level :.....	A (acc.IEC 60034-14)
○ Noise level	acc.IEC 60034-9
○ Cable entries.....	2xM32x1.5
○ Min and max admissible supply cable diameter.....	9.5-18.5mm
○ Climate execution	N

**The overall and mounting dimensions
IM 1001**

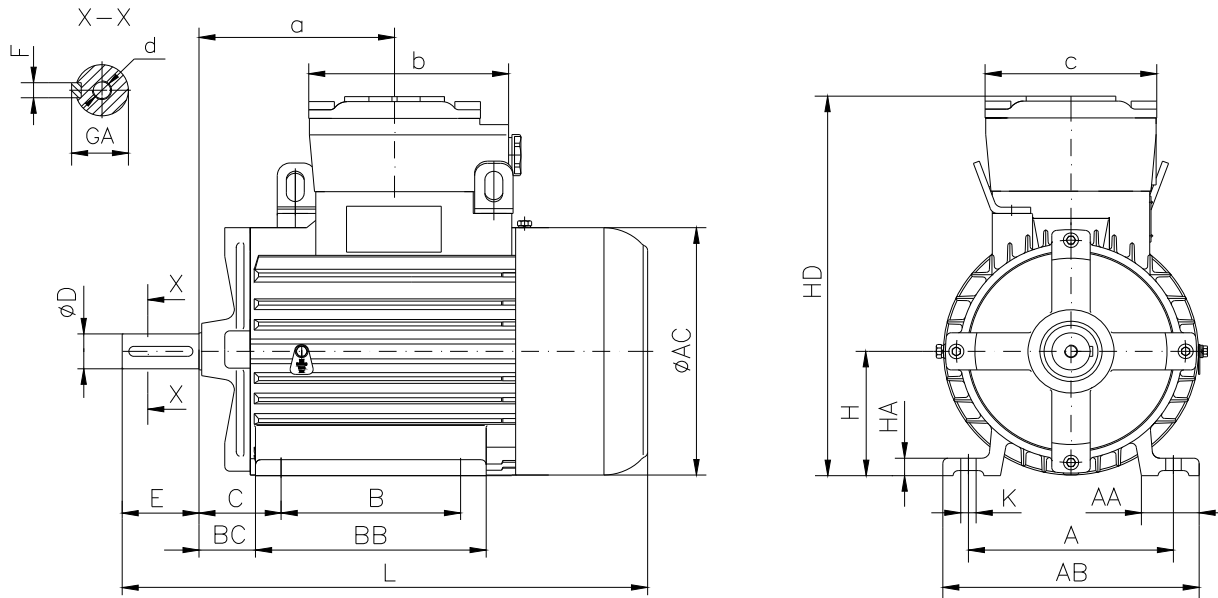

Frame size	Dimensions (mm)																				
	Foot mounting										Shaft extension					HD	AC	L	a	b	c
100 LW-2	A	B	C	H _{0.5}	K	AA	AB	BB	BC	HA	D	E	F	GA	d						
	160	140	63	100	12	45	200	180	43	14	28j6	60	8h9	31	M10	307	199	412	165	160	135

**The overall and mounting dimensions
IM 3001; IM 3011**

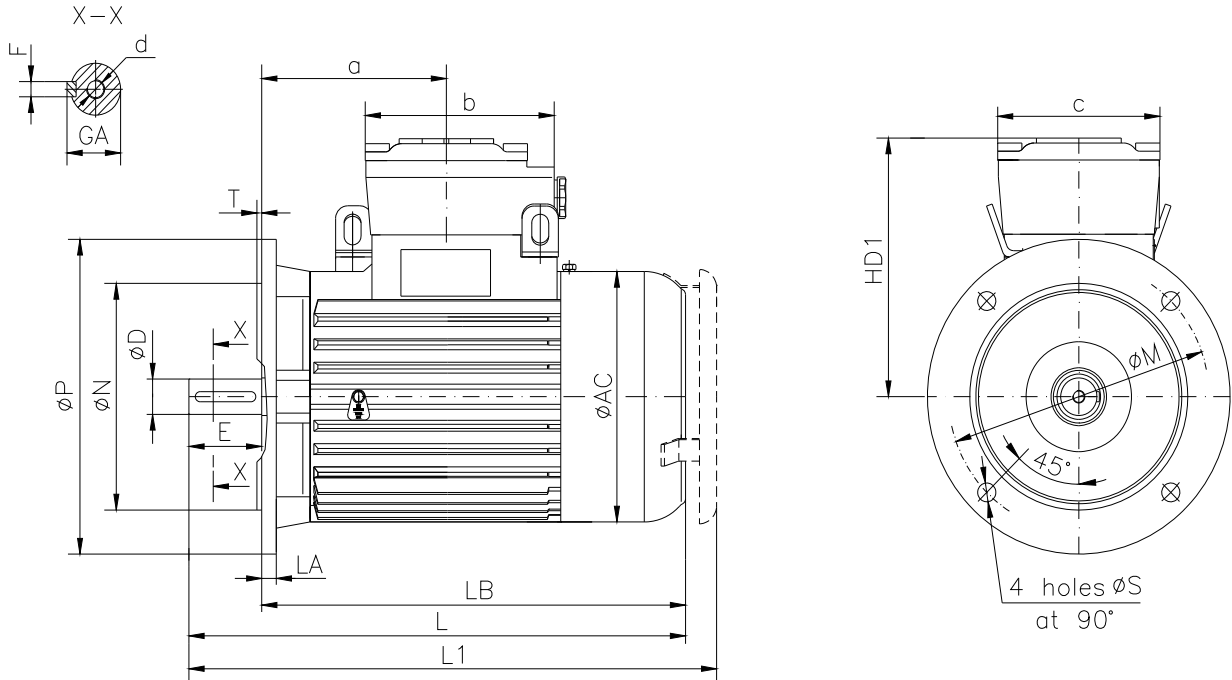

Frame size	Dimensions (mm)																		
	Flange mounting (B5)					Shaft extension					HD1	AC	LA	LB	L	L1	a	b	c
N	M	P	S	T	D	E	F	GA	d										
100 LW-2	180j6	215	250	14.5	4	28j6	60	8h9	31	M10	207	199	12	352	412	436	165	160	135

