

DATA SHEET

○ Type.....	ASA 71b-2
○ Reference standard.....	IEC 60034-1 EN 60079-0 EN 60079-1
○ Rated output.....	0.55 kW
○ Rated stator voltage.....	400V
○ Stator current at 100% load.....	1.34 [A]
○ Number of poles.....	2
○ Rated speed.....	2750 rev/min
○ Rated frequency.....	50 Hz
○ Efficiency at 100% load.....	72%
○ Power factor at 100% load.....	0.82
○ Break-down torque.....	2.7 x Mn
○ Locked rotor torque.....	2.7 x Mn
○ Locked rotor current.....	3.7 x In
○ Rotor inertia.....	0.000854 kgm ²
○ Insulation class.....	F
○ Direction of rotation.....	Both(CW&CCW)
○ Protection degree.....	≥IP55
○ Mounting.....	IM
○ Cooling method.....	IC 411
○ Max. ambient temperature.....	+40°C
○ Altitude.....	1000m
○ Bearing type.....	6203 2Z drive end 6203 2Z non drive end
○ Weight.....	18 Kg
○ Outline drawing.....	Page 2
○ Vibration level :	A (acc.IEC 60034-14)
○ Noise level	acc.IEC 60034-9
○ Cable entries.....	1xM25x1.5
○ Climate execution	N

**The overall and mounting dimensions
IM 1001**

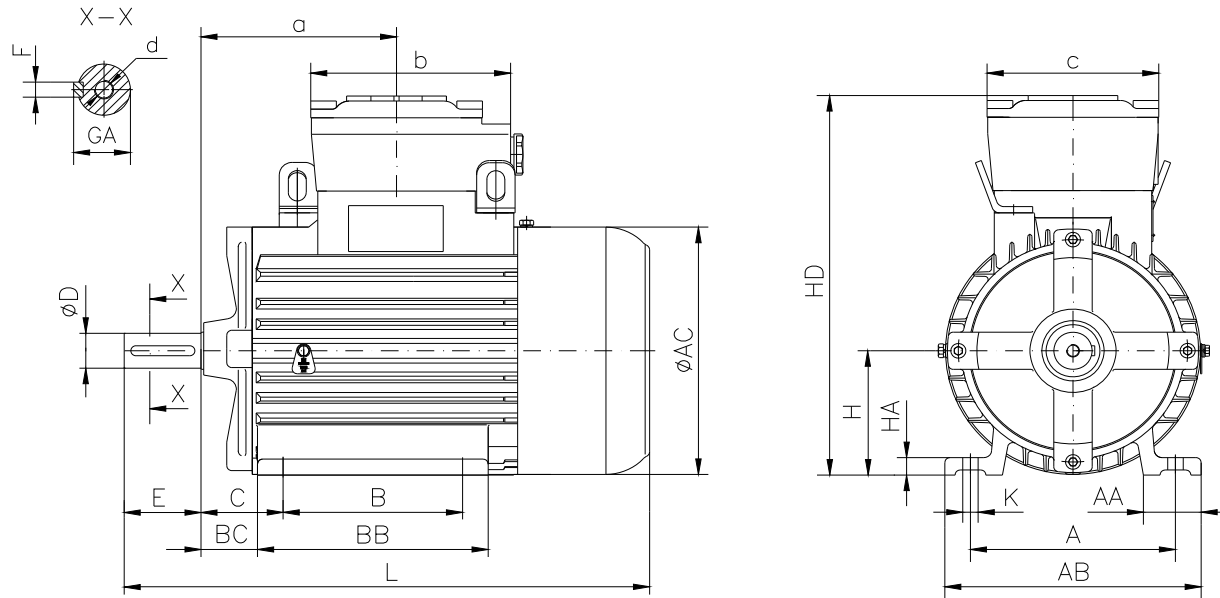

Frame size	Dimensions (mm)																				
	Foot mounting										Shaft extension						HD	AC	L	a	b
71b-2	A	B	C	H _{0.5}	K	AA	AB	BB	BC	HA	D	E	F	GA	d						
	112	90	45	71	7	37	141	125	33	9	14j6	30	5h9	16	M5	222	140	295	80	105	95

**The overall and mounting dimensions
IM 3001; IM 3011**

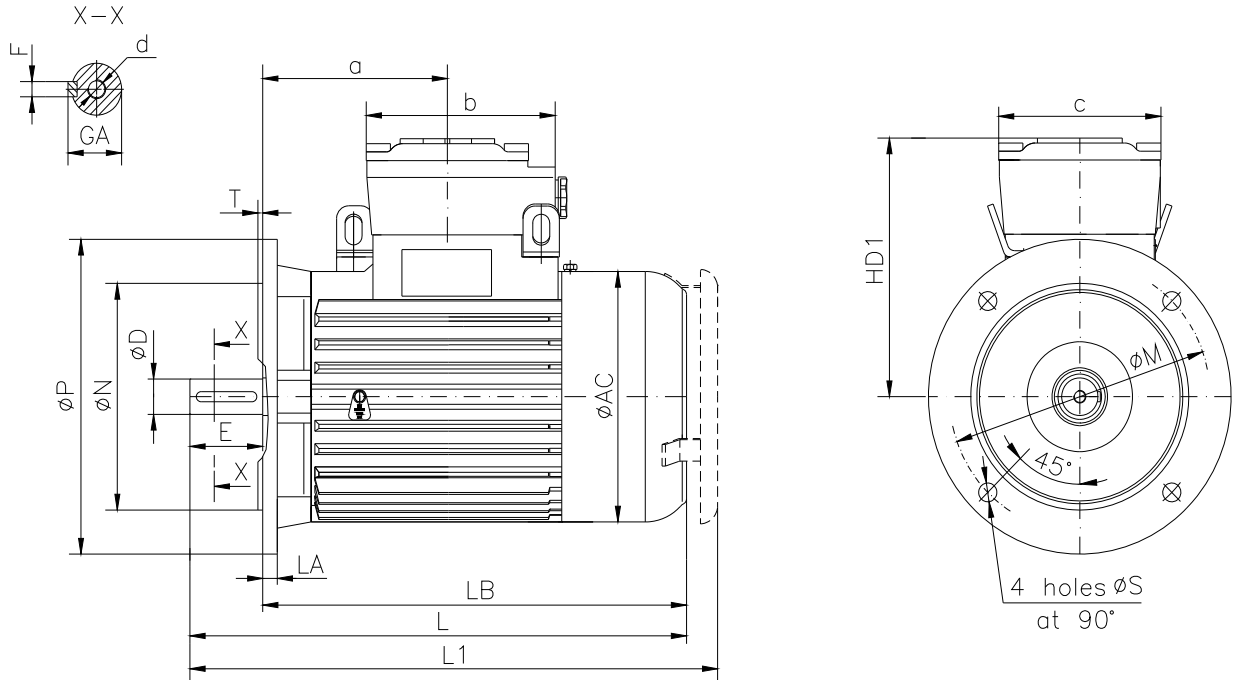

Frame size	Dimensions (mm)										HD1	AC	LA	LB	L	L1	a	b	c
	Flange mounting (B5)					Shaft extension													
	N	M	P	S	T	D	E	F	GA	d									
71b-2	110j6	130	160	10	3.5	14j6	30	5h9	16	M5	151	140	8	265	295	309	80	105	95

**The overall and mounting dimensions
IM 3601**

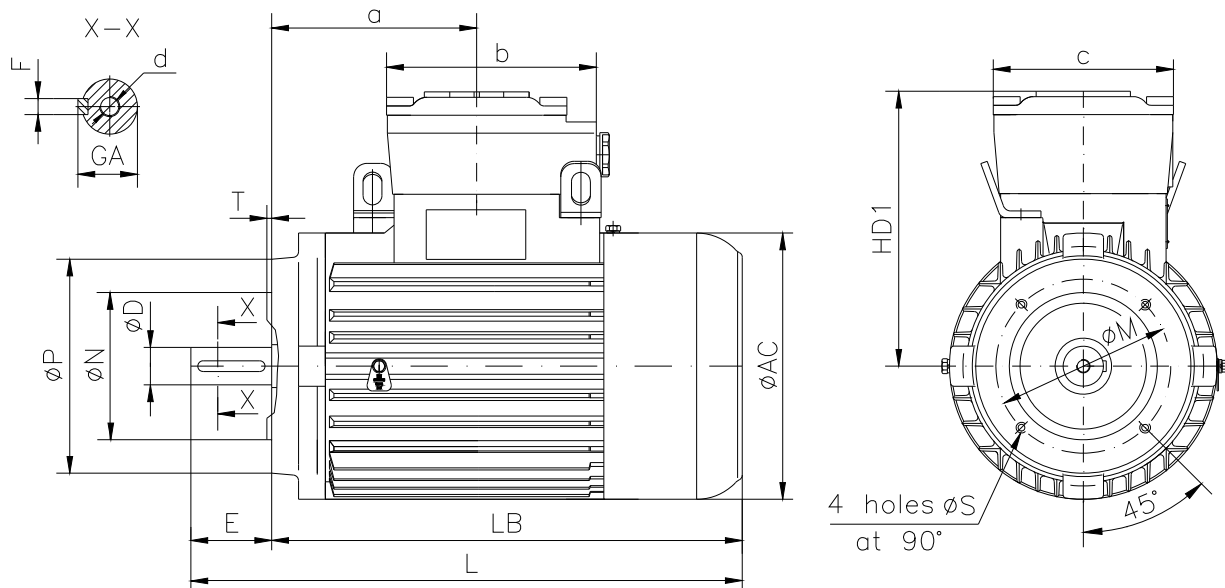

Frame size	Flange	Dimensions (mm)													
		Flange mounting (B14)					Shaft extension		HD1	AC	LB	L	a	b	c
N	M	P	S	T	D	E									
71b-2	F85	70j6	85	105	M6	2.5	14j6	30	151	140	265	295	80	105	95
	F115	95j6	115	140	M8	3									

**The overall and mounting dimensions
IM 2001**

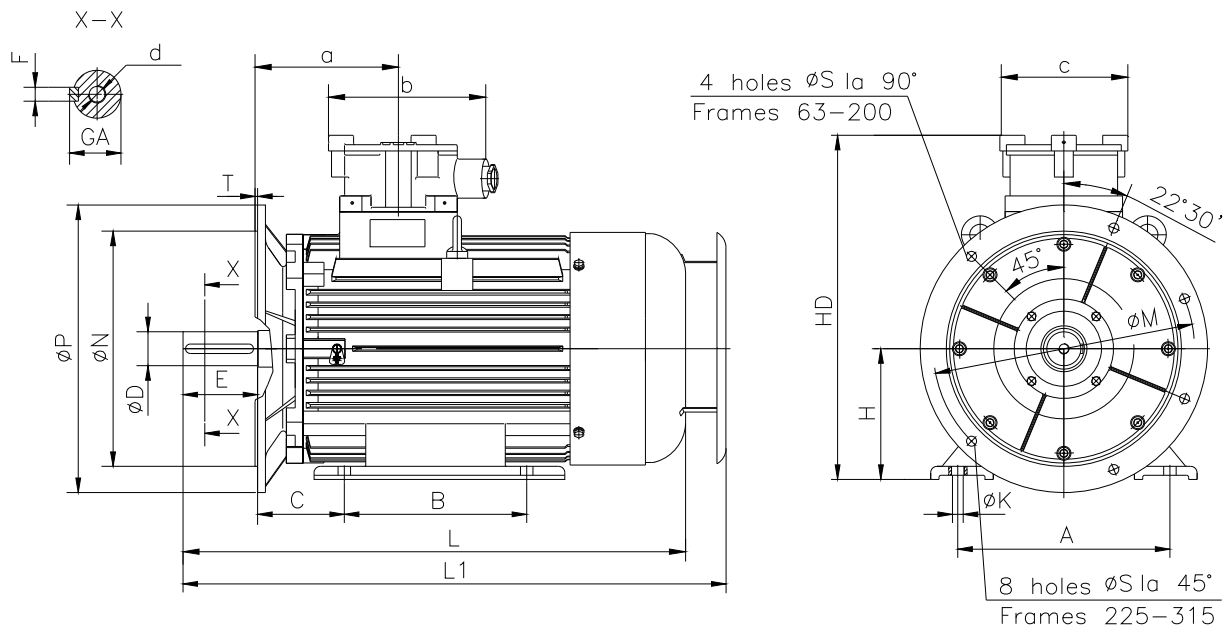

Frame size	Dimensions (mm)																				
	Foot mounting					Flange mounting					Shaft extension					HD	L	L1	a	b	c
	A	B	C	H _{0.5}	K	N	M	P	S	T	D	E	F	GA	d						
71b-2	112	90	45	71	7	110j6	130	160	10	3.5	14j6	30	5h9	16	M5	222	295	309	80	105	95