

DATA SHEET

○ Type.....	ASA 63b-2
○ Reference standard.....	IEC 60034-1 EN 60079-0 EN 60079-1
○ Rated output.....	0.25 kW
○ Rated stator voltage.....	400V
○ Stator current at 100% load	0.69 [A]
○ Number of poles.....	2
○ Rated speed.....	2772 rev/min
○ Rated frequency.....	50 Hz
○ Efficiency at 100% load.....	67.8%
○ Power factor at 100% load.....	0.77
○ Break-down torque.....	3.1 x Mn
○ Locked rotor torque.....	3.1 x Mn
○ Locked rotor current.....	3.8 x In
○ Rotor inertia.....	0.000175 kgm ²
○ Insulation class.....	F
○ Direction of rotation.....	Both(CW&CCW)
○ Protection degree.....	≥IP55
○ Mounting.....	IM
○ Cooling method.....	IC 411
○ Max. ambient temperature.....	40°C
○ Altitude.....	1000m
○ Bearing type.....	6202 2Z drive end 6202 2Z non drive end
○ Weight.....	12 Kg
○ Outline drawing.....	Page 2
○ Vibration level :	A (acc.IEC 60034-14)
○ Noise level	acc.IEC 60034-9
○ Cable entries.....	1xM25x1.5
○ Climate execution	N

**The overall and mounting dimensions
IM 1001**

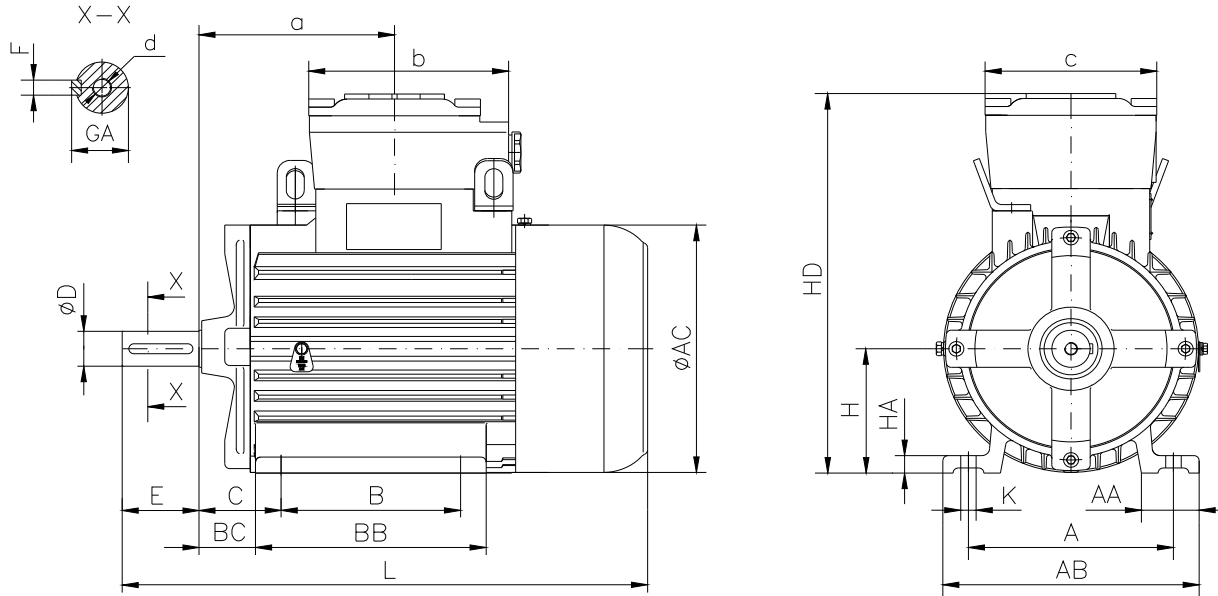

Frame size	Dimensions (mm)																				
	Foot mounting										Shaft extension					HD	AC	L	a	b	c
A	B	C	H _{0.5}	K	AA	AB	BB	BC	HA	D	E	F	GA	d							
63b-2	100	80	40	63	7	31	131	104	28.5	9	11j6	23	4h9	12.5	M4	200	125	259	100	105	95

**The overall and mounting dimensions
IM 3001; IM 3011**

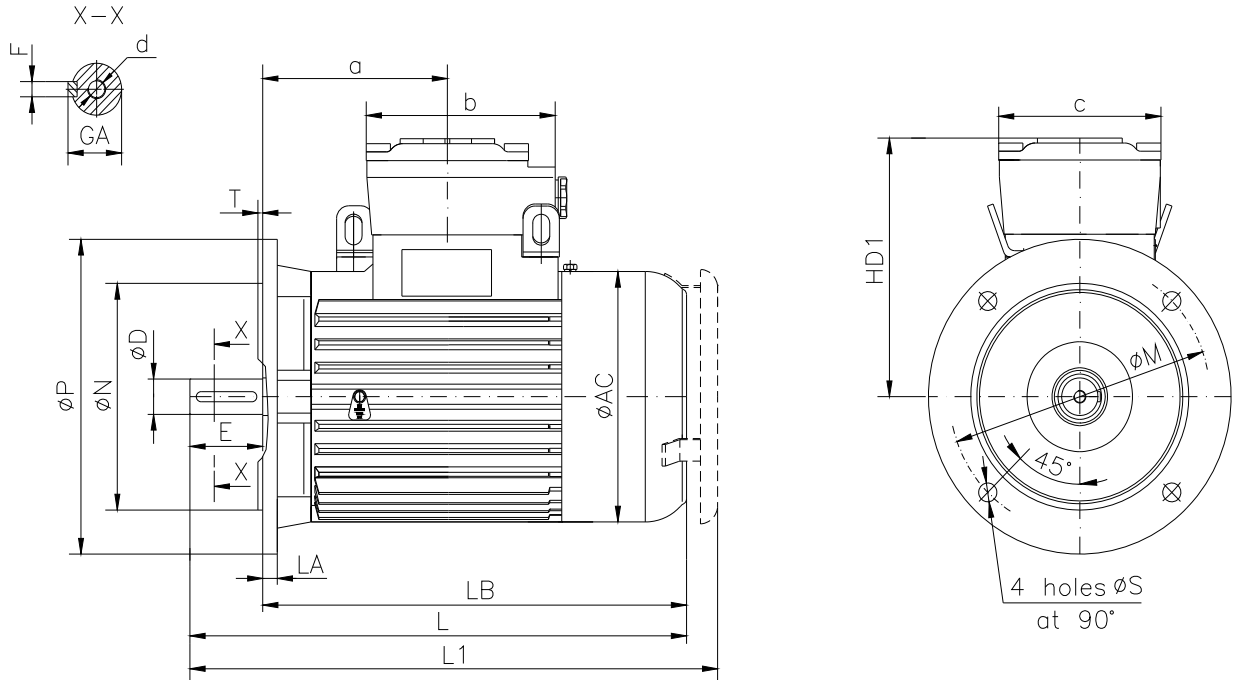

Frame size	Dimensions (mm)																		
	Flange mounting (B5)					Shaft extension					HD1	AC	LA	LB	L	L1	a	b	c
	N	M	P	S	T	D	E	F	GA	d									
63b-2	95j6	115	140	10	3	11j6	23	4h9	12.5	M4	137	125	8	236	259	273	100	105	95

**The overall and mounting dimensions
IM 3601**

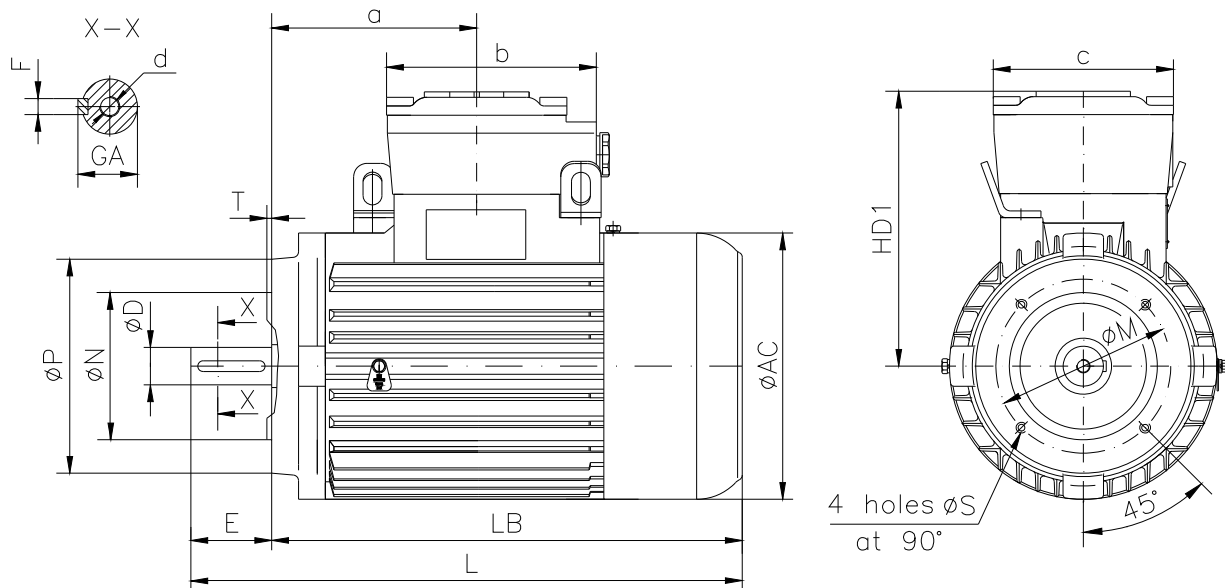

Frame size	Flange	Dimensions (mm)													
		Flange mounting (B14)					Shaft extension		HD1	AC	LB	L	a	b	c
		N	M	P	S	T	D	E							
63b-2	F75	60j6	75	90	M5	2.5	11j6	23	137	125	236	259	100	105	95
	F100	80j6	100	120	M6	3									

**The overall and mounting dimensions
IM 2001**

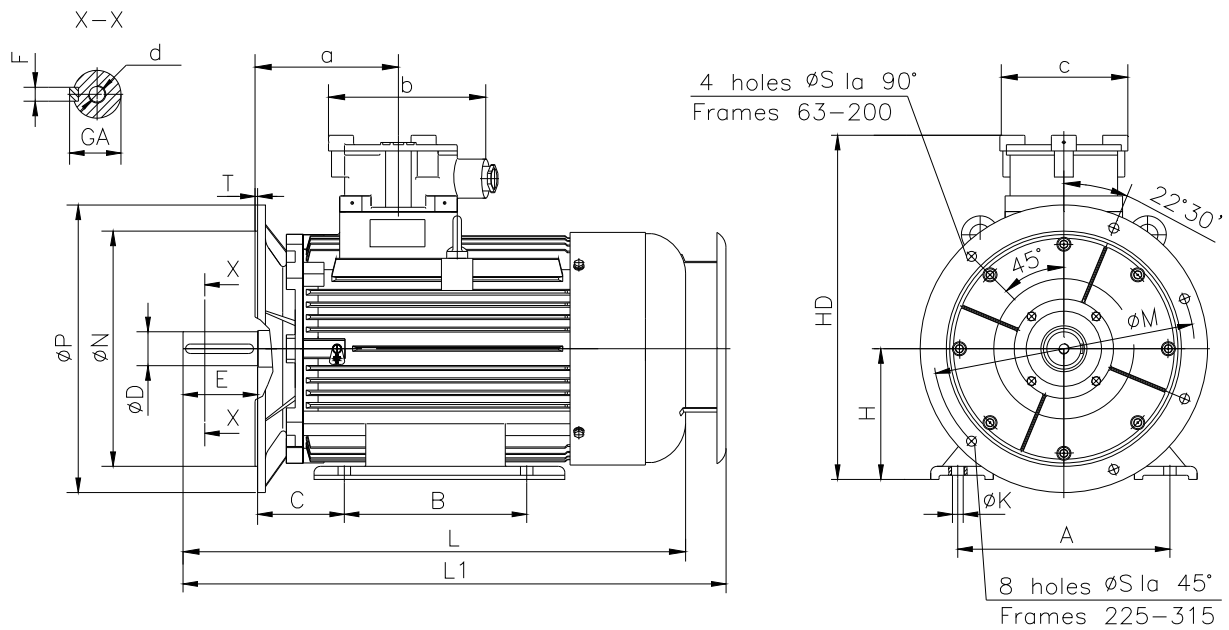

Frame size	Dimensions (mm)																				
	Foot mounting					Flange mounting					Shaft extension					HD	L	L1	a	b	c
A	B	C	H _{0.5}	K	N	M	P	S	T	D	E	F	GA	d							
63b-2	100	80	40	63	7	95j6	115	140	10	3	11j6	23	4h9	12.5	M4	200	259	273	100	105	95